

THIS COPY IS PROVIDED ON A RESTRICTED BASIS AND IS NOT TO BE USED IN ANY WAY DETRIMENTAL TO THE INTERESTS OF PANDUIT CORP.

PANDUIT PART NUMBER	STUD SIZE	DIMENSIONS in.				
		A	W	C	M	H
PV10-6RX	#6	1.10 (27.94)	.31 (7.87)	.30 (7.62)	.93 (23.62)	.15 (3.81)
PV10-8RX	#8	1.10 (27.94)	.31 (7.87)	.30 (7.62)	.93 (23.62)	.17 (4.32)
PV10-10RX	#10	1.10 (27.94)	.31 (7.87)	.30 (7.62)	.93 (23.62)	.20 (5.08)
PV10-14RX	1/4"	1.29 (32.77)	.52 (13.21)	.39 (9.91)	1.00 (25.40)	.27 (6.86)
PV10-56RX	5/16"	1.29 (32.77)	.52 (13.21)	.42 (10.67)	1.00 (25.40)	.33 (8.38)
PV10-38RX	3/8"	1.35 (34.29)	.58 (14.73)	.46 (11.68)	1.08 (27.43)	.39 (9.91)

NOTES:

1. UL LISTED AND CSA CERTIFIED FOR:

- A. 600 V. MAX BLDG WIRE (1000 V. MAX IN SIGNS, FIXTURES & LUMINAIRES), AND 14-10 AWG SOLID OR STRANDED COPPER WIRE, & 221°F (105°C MAX) TEMP RATING WITH THE CT-550 INSTALLATION TOOL.
- B. 300 V. MAX BLDG WIRE, 12-10 AWG SOLID OR STRANDED COPPER WIRE, & 167°F (75°C) MAX TEMP RATING WITH THE CT-100 & CT-250 INSTALLATION TOOLS.

2. MATERIAL:

- A. STAMPING - .04" (1.02) THK COPPER, TIN PLATED
- B. HOUSING - VINYL, YELLOW

3. STRIP LENGTH - 5/16 ^{+1/32} -0

4. PACKAGE QTY:

- L=50
- D=500

5. DIMENSIONS IN BRACKETS ARE IN MILLIMETERS

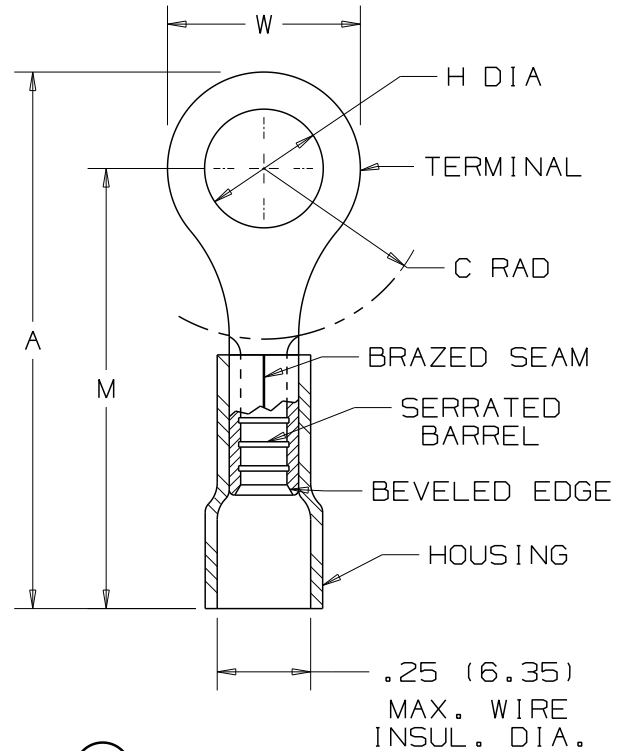

LISTED
587H
E52164



CERTIFIED
LR31212

PANDUIT CORP.

TINLEY PARK, ILLINOIS

05 8/10 SRB

Revised dimension 1.35 was 1.39
Removed tolerances

#12-10 BARREL VINYL INSULATED RING
TONGUE, .250 (6.35) MAX. WIRE
INSULATION DIAMETER

REV	DATE	BY	DESCRIPTION	DRAWN BY	CHK'D	SCALE	DRAWING NO.
				DAW	RLS	NONE	A41271