

THIS COPY IS PROVIDED ON A RESTRICTED BASIS AND IS NOT TO BE USED IN ANY WAY DETRIMENTAL TO THE INTERESTS OF PANDUIT CORP.

PANDUIT PART NUMBER	STUD SIZE	DIMENSIONS in.				
		A $\pm .03$	W $\pm .01$	C MIN	M $\pm .03$	H $\pm .01$
P12-6HDR	#6	.78 (19.81)	.31 (7.87)	.36 (9.14)	.62 (15.75)	.15 (3.81)
P12-8HDR	#8	.78 (19.81)	.31 (7.87)	.36 (9.14)	.62 (15.75)	.17 (4.32)
P12-10HDR	#10	.81 (20.57)	.37 (9.40)	.36 (9.14)	.62 (15.75)	.20 (5.08)
P12-14HDR	1/4"	.96 (24.38)	.52 (13.21)	.43 (10.92)	.70 (17.78)	.27 (6.86)
P12-56HDR	5/16"	.96 (24.38)	.52 (13.21)	.43 (10.92)	.70 (17.78)	.33 (8.38)
P12-38HDR	3/8"	1.04 (26.42)	.58 (14.73)	.48 (12.19)	.75 (19.05)	.39 (9.91)

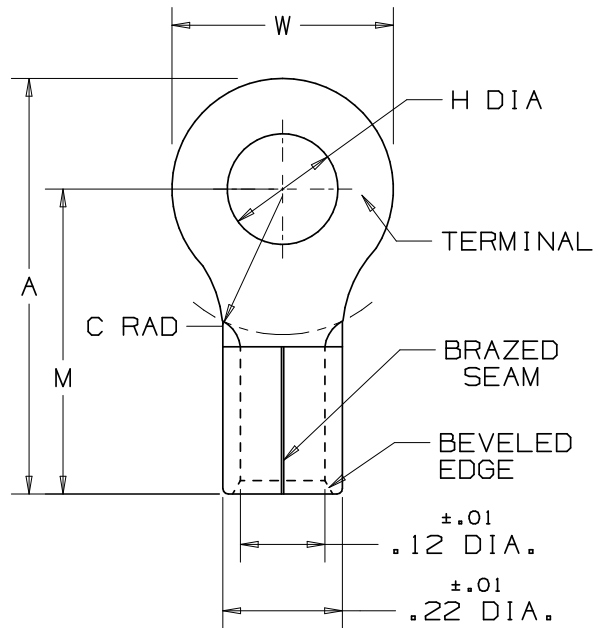

NOTES:

- UL LISTED AND CSA CERTIFIED FOR:
 - 302° F (150° C) MAX. TEMP. RATING
 - #16-12 AWG SOLID OR STRANDED COPPER WIRE
 - 2000V MAX VOLTAGE RATING
- MATERIAL: .050" (1.27) THK COPPER, TIN PLATED
- PACKAGE QTY: STD. PKG. -L=50
BULK PKG. -D=500
- INSTALLATION TOOLS: CT-100, CT-200, CT-570, CT-1570
- DIMENSIONS IN BRACKETS ARE IN MILLIMETERS.
- STRIP LENGTH - 9/32 ^{+1/32} ₀



LISTED
587H
E52164



CERTIFIED
LR31212

A41210_05

05	2/07	DAW	DAW	2000V. MAX RATING WAS 600V.	TRO0111	LCA	TRO	TINLEY PARK, ILLINOIS
04	1/01	KMD	SKB	CAD FILE SPEC. WAS N41210AA_PCD_03	08938	JAC	CCH	
03	5/99	JKD		ADDED CT-1570 TOOL	07632			#16-12 BARREL NON-INSULATED HEAVY DUTY RING TONGUE
02	7/95	MC		UPDATED NOTES AND DIMENSIONS	03437	LCA	KS	
REV	DATE	BY	CHK	DESCRIPTION	ECN #	CUST	PM	DRAWN BY: DAW CHK'D: SCALE: N/A DRAWING NO.: A41210