

THIS COPY IS PROVIDED ON A RESTRICTED BASIS AND IS NOT TO BE USED IN ANY WAY DETRIMENTAL TO THE INTERESTS OF PANDUIT CORP.

PANDUIT PART NUMBER	STUD SIZE	DIMENSIONS in.				
		A $\pm .020$	W $\pm .010$	C $\pm .015$	M $\pm .020$	H $\pm .010$
PV12-6HDR	#6	1.05 (26.67)	.31 (7.87)	.35 (8.89)	.89 (22.61)	.15 (3.81)
PV12-8HDR	#8	1.05 (26.67)	.31 (7.87)	.35 (8.89)	.89 (22.61)	.17 (4.32)
PV12-10HDR	#10	1.08 (27.43)	.37 (9.40)	.33 (8.38)	.89 (22.61)	.20 (5.08)
PV12-14HDR	1/4"	1.23 (31.24)	.52 (13.21)	.42 (10.67)	.97 (24.64)	.27 (6.86)
PV12-56HDR	5/16"	1.23 (31.24)	.52 (13.21)	.42 (10.67)	.97 (24.64)	.34 (8.64)
PV12-38HDR	3/8"	1.31 (33.27)	.58 (14.73)	.46 (11.68)	1.02 (25.91)	.40 (10.16)

NOTES:

- UL LISTED AND CSA CERTIFIED FOR:
 - 600V. MAX. VOLTAGE RATING
 - #16-12 AWG STRANDED COPPER WIRE
 - 221° F (105° C) MAX. TEMP. RATING
- MATERIAL:
 - STAMPING - .05" (1.27) THK COPPER, TIN PLATED
 - HOUSING - VINYL, YELLOW
- PACKAGE QTY: STD. PKG. 50
BULK PKG. 500
- DIMENSIONS IN BRACKETS ARE IN MILLIMETERS
- INSTALLATION TOOLS:
 - UL LISTED AND CSA CERTIFIED: CT-550, CT-1550 & CT-1551
 - PANDUIT APPROVED: CT-460

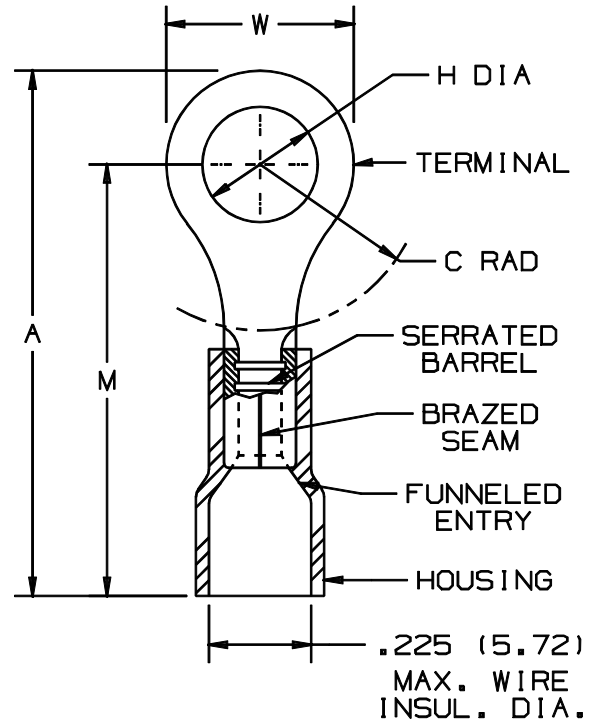

LISTED
587H
E52164



CERTIFIED
LR3122

A41281_02

												TINLEY PARK, ILLINOIS			
02		JKD		ADDED CT-1550 & CT-1551 TO NOTE 5								#16-12 BARREL FUNNELED VINYL INSULATED HEAVY DUTY RING TONGUE, .225 (5.72) MAX. WIRE INSULATION DIAMETER			
1	7-88	DW		REDRAWN WITH REVISIONS											
REV	DATE	BY	CHK	DESCRIPTION				ECN	PM	APP	DRAWN BY	CHK'D	SCALE	DRAWING NO.	
											DAW		NONE	A41281A	