

4

3

2

1

THIS DRAWING IS UNPUBLISHED. RELEASED FOR PUBLICATION
 © COPYRIGHT - By - ALL RIGHTS RESERVED.

LOC	DIST	REVISIONS			
P	LTR	DESCRIPTION	DATE	DWN	APVD
G	14	G1	REVISED PER ECO-11-005027	11MAR11	RK HMR

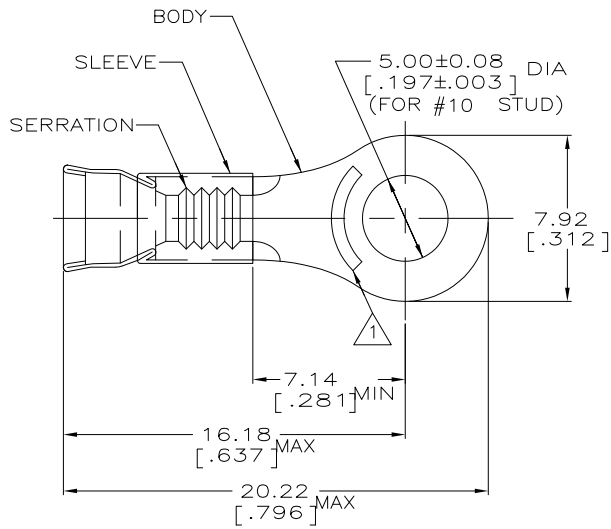

- 1 SEE TABLE FOR STAMPING
 22-16 TERMINALS ARE STAMPED 22-18 IN
 ACCORDANCE WITH MILITARY SPEC MIL-T-7928
 COMMERCIAL WIRE RANGE IS 22-16
2. WIRE INSUL DIA, 2.67-3.56 [.105-.140]
3. TONGUE MATL THK, 0.79±0.05 [.031±.002]
- 4 PRELIMINARY - NOT FOR PRODUCTION

4	AMP 22-18	NICKEL PER ASTM B162	ORANGE	5000	ON TAPE, REEL	1-321898-1
	AMP22-18AL	ALUMEL	GREEN	500	LOOSE PIECE	1-321898-0
	AMP 22-18	NICKEL PER ASTM B162	ORANGE	1000	LOOSE PIECE	321898
	STAMPING	BODY MATERIAL	SLV COLOR	QTY	PACKAGE TYPE	PART NO

AMP INCORPORATED CUSTOMER SERVICE SYSTEM		MAX RECOMMENDED OPERATING TEMPERATURE: 649° C [1200° F]	THIS DRAWING IS A CONTROLLED DOCUMENT.		DWN L OLMEDA 100CT94	TE Connectivity	
FOR ADDITIONAL PRODUCT INFORMATION OR COPIES OF DRAWINGS AND TECHNICAL DOCUMENTS	PRODUCT INFORMATION CENTER 1-800-522-6752		DIMENSIONS: mm [INCHES]	TOLERANCES UNLESS OTHERWISE SPECIFIED:			
FOR APPLICATION TOOLING INFORMATION	TOOLING ASSISTANCE CENTER 1-800-722-1111	VOLTAGE RATING: -			APVD S BORTNER 100CT94	NAME TERMINAL, RING TONGUE, STRATOTHERM, DIAMOND GRIP, 22-16 AWG	
FOR ORDER ENTRY	1-800-526-5142	CIRCULAR MIL AREA: 0.26mm ² - 1.65mm ² [509-3260]	MATERIAL BODY, SEE TABLE SLEEVE, NI SIL PER ASTM B122	FINISH SLV COLOR, SEE TABLE	PRODUCT SPEC -	APPLICATION SPEC -	RESTRICTED TO -
1470-19 (3/11)		STRANDED WIRE	WEIGHT -		SIZE A3	CAGE CODE 00779	DRAWING NO C-321898
CUSTOMER DRAWING					SCALE 6:1	SHEET 1 OF 1	REV G1