

4
 THIS DRAWING IS UNPUBLISHED. RELEASED FOR PUBLICATION
 COPYRIGHT 19 BY AMP INCORPORATED. ALL INTERNATIONAL RIGHTS RESERVED.

LOC	QTY	REV	ZONE	LTR	DESCRIPTION	DATE	APPO
G	14				REV & REDRAWN PER 0720-0104-93	7/6/93	QDAP

METRIC
 DIMENSIONS LISTED IN mm [INCHES]

AMP WIRE RANGE	E13288 Listed
26-22 AWG SOLID OR STRANDED	NOT LISTED
LR7189 Certified	MILITARY P/N AND CLASS
NOT CERTIFIED	NOT APPLICABLE

STAMP AMP APPROX AS SHOWN

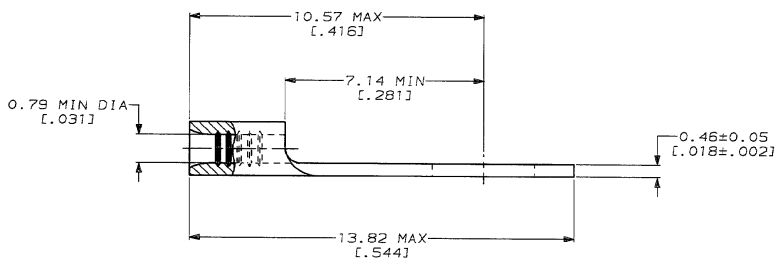
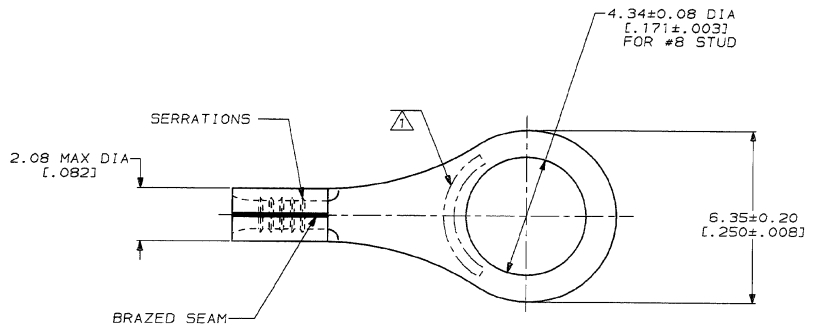

LOOSE PIECE	GOLD PLATE 0.00127 [.000050] MIN THK PER MIL-G-45204 OVER NICKEL PLATE 0.000762 [.000030] MIN THK PER QQ-N-290	55778-1
PACKAGE TYPE	FINISH	PART NO

**AMP INCORPORATED
 CUSTOMER SERVICE SYSTEMS**

FOR ADDITIONAL PRODUCT INFORMATION OR COPIES OF DRAWINGS AND TECHNICAL DOCUMENTS	PRODUCT INFORMATION CENTER 1-800-522-6752
FOR APPLICATION TOOLING INFORMATION	TOOLING ASSISTANCE CENTER 1-800-722-1111
FOR ORDER ENTRY	1-800-526-5142

MAX RECOMMENDED OPERATING TEMPERATURE:	170°C
VOLTAGE RATING:	NOT APPLICABLE
WIRE CROSS SECTIONAL AREA RANGE:	0.1-0.41mm ² (202-810) CIR MILS SOLID OR STRANDED
THIS DRAWING IS A CONTROLLED DOCUMENT FOR AMP INCORPORATED. IT IS SUBJECT TO CHANGE AND THE CONTROLLING ENGINEERING ORGANIZATION SHOULD BE CONTACTED FOR THE LATEST REVISION.	

DO NOT SCALE PRINT. UNLESS SPECIFIED DIMENSIONS ARE IN INCHES TOLERANCES ON: 2 PL DEC = - 3 PL DEC = - ANGLES = -	DR 6-15-93 TA BRINKMAN CHK 6-15-93 DA PATTERSON APPO 6-15-93 DE MILLER APPO 6-15-93 JL MECKLEY PRODUCT SPEC -
MATERIAL COPPER PER ASTM B-152 ANNEALED	FINISH SEE TABLE

AMP AMP Incorporated Harrisburg, PA 17105-3608			
NAME TERMINAL, RING TONGUE, SOLISTRAND™			
SIZE	CAGE CODE	DRAWING NO	
©	00779	©55778	
SCALE	10:1	SHEET	1 OF 1