

4

3

2

1

THIS DRAWING IS UNPUBLISHED. RELEASED FOR PUBLICATION
 © COPYRIGHT - BY TYCO ELECTRONICS CORPORATION. ALL RIGHTS RESERVED.

LOC	DIST	REVISIONS			
P	LTR	DESCRIPTION	DATE	DWN	APVD
G	14				
	K2	REV PER ECR 09-026074	30NOV09	JR	TM

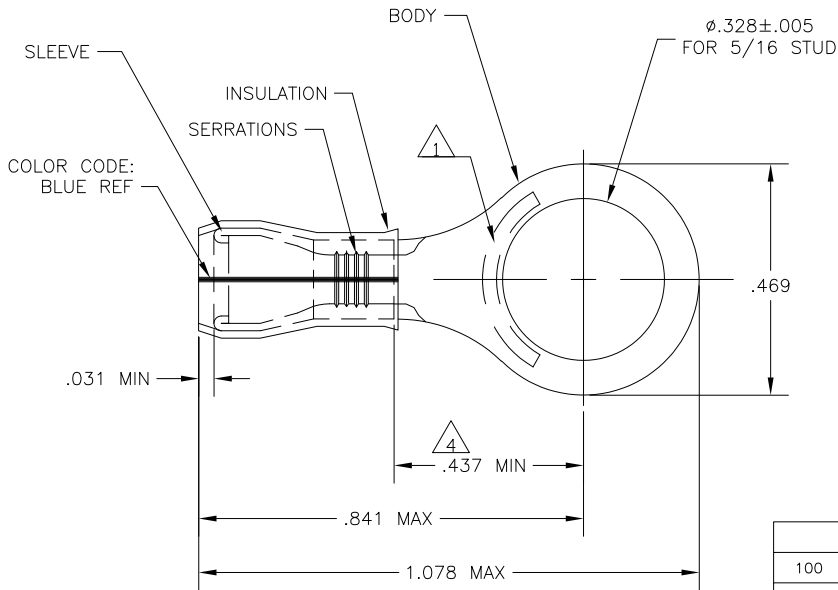

- 1 STAMP AMP 16-14* APPROX AS SHOWN
- 2 WIRE INSULATION DIA: .105-.150
- 3 TONGUE MATERIAL THK: .031±.002
- 4 APPLIES FROM EDGE OF METAL WIRE BARREL TO CENTER OF STUD HOLE.
- 5 MEETS M7928/4-109, CLASS 1 & 2
MEETS M7928/13-109, CLASS 2

QTY	PACKAGE TYPE	MATERIAL & FINISH	PART NO
100	LOOSE PIECE, BOX	SAME AS 53420-1	8-53420-1
BULK	LOOSE PIECE	SAME AS 53420-1	8-53420-0
1000	LOOSE PIECE	BODY: COPPER PER ASTM B152 TIN/LEAD (93-7) PLATE PER ASTM B545 (3% MIN LEAD CONTENT) SLEEVE: COPPER PER ASTM B152 TIN/LEAD (93-7) PLATE PER ASTM B545 (3% MIN LEAD CONTENT) INSULATION: PVF2, COLOR-NATURAL	53420-1

THIS DRAWING IS A CONTROLLED DOCUMENT.		DWN JR RUTH 25OCT07	Tyco Electronics Corporation Harrisburg, Pa 17105-3608	
DIMENSIONS: INCHES	TOLERANCES UNLESS OTHERWISE SPECIFIED:	CHK T MICHELUTTI 25OCT07	NAME T MICHELUTTI	
	0 PLC ± -	APVD T MICHELUTTI 25OCT07	PRODUCT SPEC	
	1 PLC ± -		APPLICATION SPEC	
	2 PLC ± -		SIZE	CAGE CODE
	3 PLC ± .008		A3	00779
	4 PLC ± -		DRAWING NO	53420
	ANGLES ± -		RESTRICTED TO	
MATERIAL SEE TABLE	FINISH SEE TABLE	WEIGHT -	CUSTOMER DRAWING	
			SCALE	4:1
			SHEET	1 OF 1
			REV	K2

AMP 1470-19 REV 31MAR2000