

4

3

2

1

THIS DRAWING IS UNPUBLISHED. RELEASED FOR PUBLICATION
 BY TYCO ELECTRONICS CORPORATION. ALL INTERNATIONAL RIGHTS RESERVED.

LOC	DIST	REVISIONS					
G	14	P	LR	DESCRIPTION	DATE	BY	APPD
		E1		REV PER EDR 09-027840	230E009	JR	TM

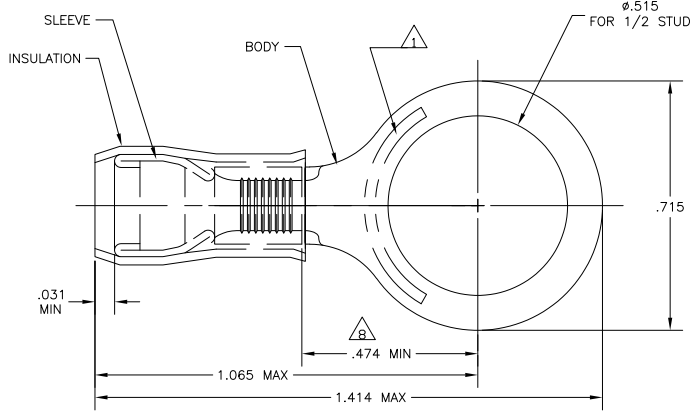

STYLE A

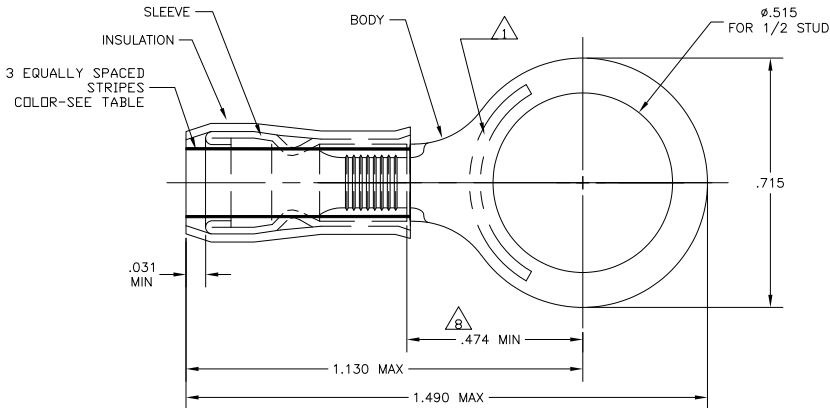

STYLE B
INSULATION RESTRICTING

- △ STAMP "AMP - SEE TABLE" APPROX AS SHOWN
- 2 WIRE INSULATION DIA: SEE TABLE
- 3 TONGUE MATERIAL THK: .040±.002
- △ BODY: TIN PLATE .000100 MIN EXT THK PER ASTM B545
- △ SLEEVE: TIN PLATE .000100 MIN EXT THK PER ASTM B545
- △ SLEEVE: NICKEL PLATE PER QQ-N-290
- △ BODY & SLEEVE- CU PER ASTM B152
INSULATION - NYLON PER ASTM D4066
COLOR - YELLOW
- △ APPLIES FROM EDGE OF METAL WIRE BARREL TO CENTER OF STUD HOLE.
- △ MEETS MS25036-158, CLASS 2
- △ MEETS M7928/1-62, CLASS 2
- △ MEETS M7928/1-69, CLASS 2

QTY	PACKAGE TYPE	STAMPING	WIRE INSUL DIA	WIRE SIZE	STRIP COLOR	STYLE	BODY FINISH	SLEEVE FINISH	PART NO
500	LOOSE PIECE	10	.119-.200	10	BROWN	B	△	△	52077-2
500	LOOSE PIECE	12	.095-.200	12	YELLOW	B	△	△	52077-1
500	LOOSE PIECE	12-10	.150-.230	12-10	---	A	△	△	52077

CUSTOMER SERVICE SYSTEMS	
FOR ADDITIONAL PRODUCT INFORMATION OR COPIES OF DRAWINGS AND TECHNICAL DOCUMENTS	PRODUCT INFORMATION CENTER 1-800-522-6752
FOR APPLICATION	TOOLING ASSISTANCE CENTER 1-800-722-1111
TOOLING INFORMATION	1-800-722-1111
FOR ORDER ENTRY	1-800-526-5142

MAX RECOMMENDED OPERATING TEMPERATURE: 105°C MAX	VOLTAGE RATING: 300 VOLT MAX	CIRCULAR MIL AREA: 2.62-6.64mm ² (5,180-13,100) STRANDED OR SOLID
THIS DRAWING IS A CONTROLLED DOCUMENT.		
DIMENSIONS: INCHES		
OTHER DIMENSIONS UNLESS OTHERWISE SPECIFIED:		
0 PLG	± .005	
1 PLG	± .005	
2 PLG	± .005	
3 PLG	± .008	
4 PLG	± .010	
ANGLES	± .010	
FINISH		
MATERIAL		

DR: JR. RUTH	230E009	Tyco Electronics Corporation
CHK: T. MICHELJUTTI	230E009	Harrisburg, PA 17105-3608
APPD: T. MICHELJUTTI	230E009	NAME
PRODUCT SPEC:		TERMINAL, RING TONGUE, PIDG
APPLICATION SPEC:		WIRE SIZE: 12-10 AWG
WEIGHT:		SIZE: A2
CAGE CODE:	00779	WIRE SIZE: 12-10 AWG
DRAWING NO:	52077	RESTRICTED TO:
CUSTOMER DRAWING		SCALE: 5:1 SHEET 1 of 1 REV E1

1471-9 (1/08)

52077

A