

4

3

2

1

THIS DRAWING IS UNPUBLISHED. RELEASED FOR PUBLICATION
 © COPYRIGHT - BY TYCO ELECTRONICS CORPORATION. ALL RIGHTS RESERVED.

LOC	DIST	REVISIONS			
P	LTR	DESCRIPTION	DATE	DWN	APVD
G	14				
	C1	REV PER ECR 09-026074	30NOV09	JR	TM

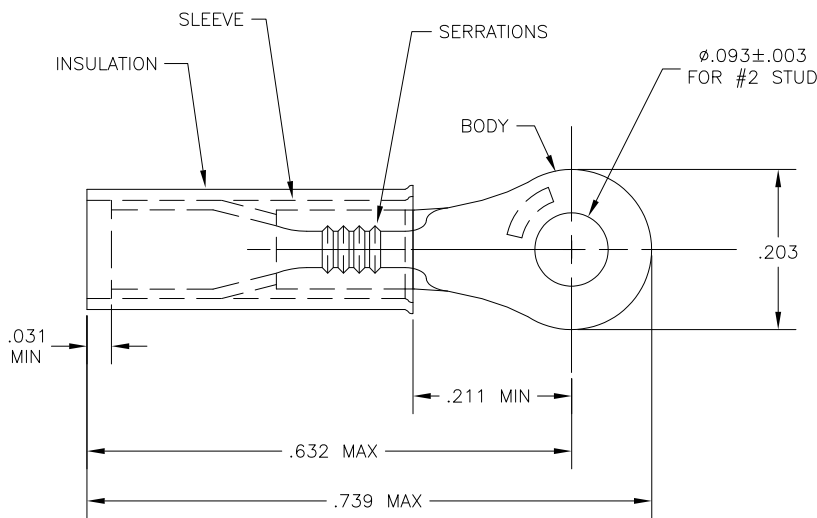

- 1 TONGUE MATERIAL THK IS $.027 \pm .001$
- 2 FOR $.050$ TO $.105$ WIRE INS. DIA.
- 3 MUST BE CRIMPED WITH 22-18 OR 22-16 PIDG (RED) TOOL.
- 4 MEETS MS25036-143, CLASS 1 & 2

1	54310-1	BODY: COPPER ASTM B152 TIN PL PER ASTM B545 SLEEVE: COPPER ASTM B152 TIN PL PER ASTM B545 INSULATION: NYLON, COLOR: YELLOW
QTY	PART NO	MATERIAL & FINISH

THIS DRAWING IS A CONTROLLED DOCUMENT.		DWN	JR RUTH	27JAN04	Tyco Electronics Corporation Harrisburg, Pa 17105-3608
DIMENSIONS: INCHES		CHK	T MICHELUTTI	27JAN04	
TOLERANCES UNLESS OTHERWISE SPECIFIED: 0 PLC ± - 1 PLC ± - 2 PLC ± - 3 PLC ± .008 4 PLC ± - ± 1°		APVD	T MICHELUTTI	27JAN04	NAME
MATERIAL SEE TABLE		FINISH SEE TABLE		PRODUCT SPEC APPLICATION SPEC WEIGHT SIZE CAGE CODE DRAWING NO A3 00779 C-54310	
		CUSTOMER DRAWING		SCALE	8:1
				SHEET	1 OF 1
				REV	C1