

4

3

2

1

THIS DRAWING IS UNPUBLISHED. RELEASED FOR PUBLICATION
 © COPYRIGHT - BY TYCO ELECTRONICS CORPORATION. ALL INTERNATIONAL RIGHTS RESERVED.

LOC	DIST	REVISIONS				
P	LTR	DESCRIPTION	DATE	DWN	APVD	
AF	50					
	D	REVISED PER ECR-10-006099	09JUL10	HMR	PD	

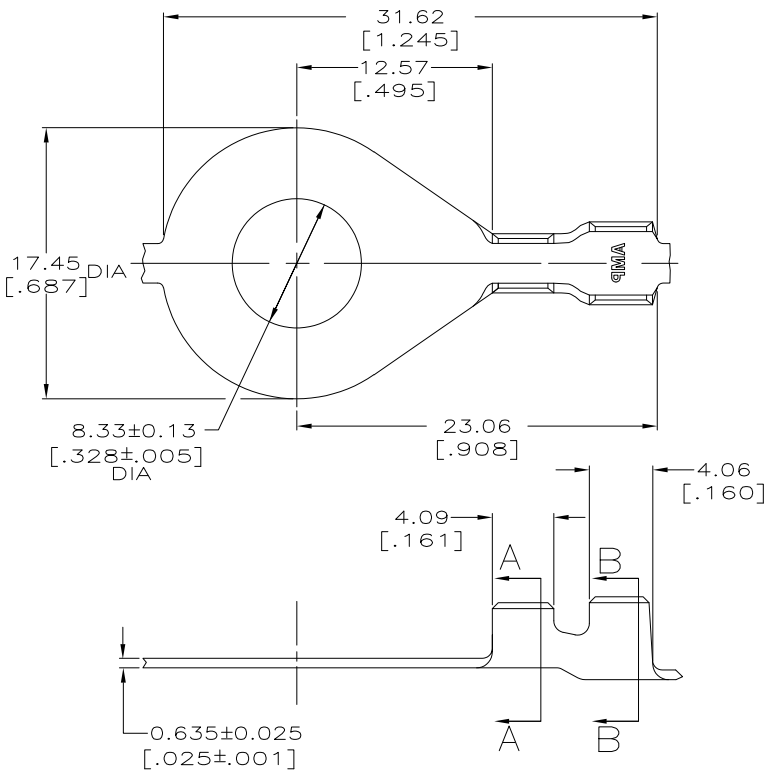

1. CONTINUOUS STRIP ON REEL.

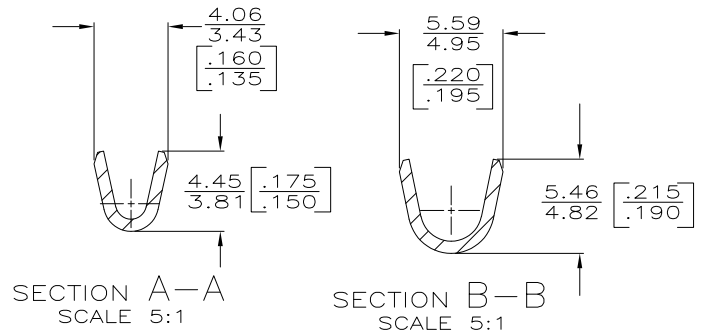

TIN	082 BRASS	2.29-3.68	2.29-3.68 DIA	[18-14] AWG	62787-2
	TEMP A SST	[.090-.145]	[.090-.145] DIA	[18-14] AWG	62787-1
FINISH	MATERIAL	INSULATION RANGE	WIRE RANGE	PART NO	

THIS DRAWING IS A CONTROLLED DOCUMENT.		DWN PHILLIP M. FORTNEY 30/JAN/96	Tyco Electronics Corporation Harrisburg, PA 17105-3608		
DIMENSIONS: mm [INCHES]		CHK JEFF R RUTH 30/JAN/96	RING		
TOLERANCES UNLESS OTHERWISE SPECIFIED:		APVD GARY YETTER 30/JAN/96	NAME		
0 PLC ± -		PRODUCT SPEC			
1 PLC ± -		APPLICATION SPEC			
2 PLC ± 0.25 [010]		SIZE			
3 PLC ± -		CAGE CODE			
4 PLC ± -		DRAWING NO			
ANGLES ± -		RESTRICTED TO			
MATERIAL	FINISH	WEIGHT	A3	00779	62787
SEE TABLE	SEE TABLE	CUSTOMER DRAWING	SCALE 4:1	SHEET 1 OF 1	REV D