

DRAWING MADE IN THIRD ANGLE PROJECTION

THIS DRAWING IS UNPUBLISHED. RELEASED FOR PUBLICATION  
 © COPYRIGHT 19 BY AMP INCORPORATED. ALL INTERNATIONAL RIGHTS RESERVED.

LOC	DIST	P	F	ZONE	LTR	DESCRIPTION	DATE	APPD
AF	50				A	RELEASE PER FASR, REV PER AF-8005	6/23/92	PF/GY

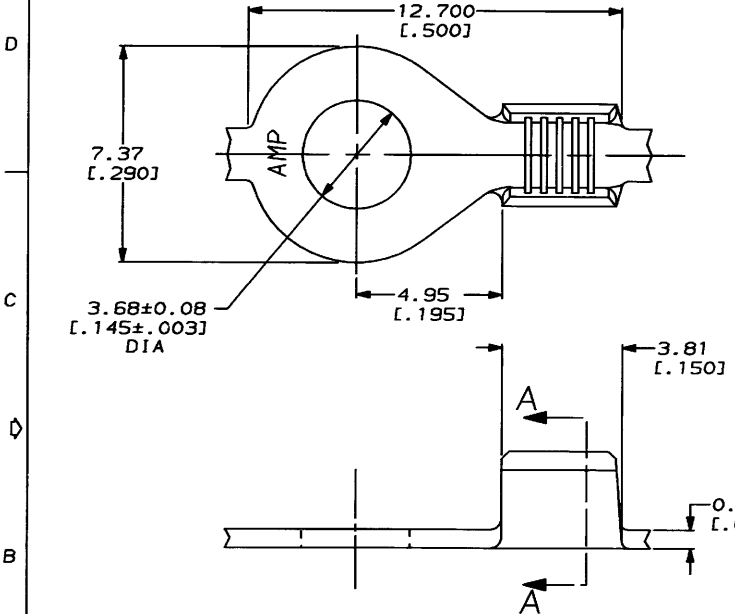

1 CONTINUOUS STRIP ON REEL.

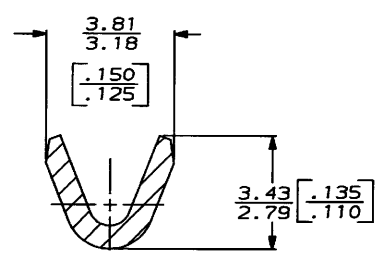

SECTION A-A  
SCALE 10:1

F	2.79	1.47 [058]	0.8 [18]	DO NOT SCALE PRINT. UNLESS SPECIFIED DIMENSIONS IN MM (INCHES) TOLERANCES ON: 3 PLC DEC = 0.25 (.010) ANGLES = -	DR 5/6/92	AMP AMP Incorporated Harrisburg, PA 17105-3608
	[.110]	1.40 [055]	0.6 [20]		CHK 5/6/92	
TYPE	WIDTH	HEIGHT	WIRE	MATERIAL	APPD 5/6/92	RING, AMPLIVAR
				082 BRASS	G YETTER	
WIRE BARREL CRIMP				FINISH	PRODUCT SPEC	NAME
THIS DRAWING IS A CONTROLLED DOCUMENT FOR AMP INCORPORATED. IT IS SUBJECT TO CHANGE AND THE CONTROLLING ENGINEERING ORGANIZATION SHOULD BE CONTACTED FOR THE LATEST REVISION.				0.002032 [0.00080]	APPLICATION SPEC	SIZE
				MIN TIN PL	WEIGHT	CAGE CODE
				PER MIL-T-10727		DRAWING NO
						00779
						SCALE
						8:1
						SHEET
						1 OF 1

0.64-1.02mm DIA [22-18] AWG  
MAGNET WIRE RANGE  
63649-1  
PART NO

AMP 1470-15 REV 3-82  
23 JUN 1992 10:01:05 AMP17795

<U5126A>DEPT2122>DM62122>U.R.S

CUSTOMER DRAWING