

4

3

2

1

THIS DRAWING IS UNPUBLISHED. RELEASED FOR PUBLICATION
 © COPYRIGHT 19 BY AMP INCORPORATED. ALL RIGHTS RESERVED.

LOC	DIST	REVISIONS				
P	LTR	DESCRIPTION	DATE	DWN	APVD	
R		ADDED -3 AND REDRAWN PER QL10-0077-97	11/FEB/97	PF	GY	

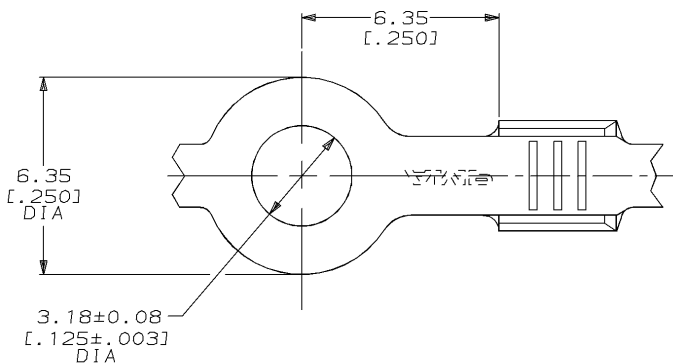

1 CONTINUOUS STRIP ON REEL.

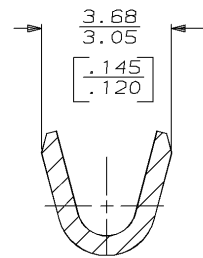

SECTION A-A
SCALE 10:1

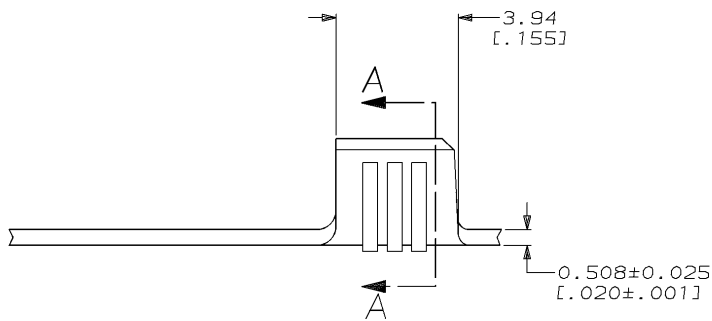

H02 PHOS BRZ	[22-16] AWG	42185-3
082 BRASS		42185-2
MATERIAL	WIRE RANGE	PART NUMBER

THIS DRAWING IS A CONTROLLED DOCUMENT.

DIMENSIONS: mm (INCHES)	TOLERANCES UNLESS OTHERWISE SPECIFIED:	DWN PHILLIP M FORTNEY 11/FEB/97	AMP Incorporated Harrisburg, PA 17105-3608	
0 PLC ±-	1 PLC ±-	CHK JEFF R RUTH 11/FEB/97	AMP TERMINAL, RING	
2 PLC ±0.25 (.010)	3 PLC ±-	APVD GARY YETTER 11/FEB/97		
4 PLC ±-	ANGLES ±-	PRODUCT SPEC		
MATERIAL SEE TABLE	FINISH 0.002032 [.000080] MIN TIN PL PER MIL-T-10727	APPLICATION SPEC		
		WEIGHT -	SIZE A3	CAGE CODE 00779
		CUSTOMER DRAWING	DRAWING NO C-42185	RESTRICTED TO
			SCALE 8:1	SHEET 1 OF 1
				REV R

AMP 1470-19 REV 27JUN86

11-FEB-97 09:27:21 amp17795 /vs/dep12122/dwg2122/u.rs