

THIS DRAWING IS UNPUBLISHED. RELEASED FOR PUBLICATION
 © COPYRIGHT 19 BY AMP INCORPORATED. ALL INTERNATIONAL RIGHTS RESERVED.

LOC	DIST	P	F	ZONE	LTR	REVISIONS	DATE	APPD
G	14					F REV, RDRW, & SM PKG PER 0720-0061-93	4-15-93	APD

METRIC
 DIMENSIONS LISTED IN mm [INCHES]

AMP WIRE RANGE	UL E13288 Listed
22-16 AWG SOLID OR STRANDED	NOT APPLICABLE
UL LR7189 Certified	MILITARY P/N AND CLASS
NOT APPLICABLE	NOT APPLICABLE

- ⚠ STAMP AMP 22-18 APPROX AS SHOWN
22-16 TERMINALS ARE STAMPED 22-18 IN ACCORDANCE WITH MILITARY SPECIFICATION MIL-T-7928; COMMERCIAL WIRE RANGE IS 22-16
- ⚠ WIRE BARREL COLOR CODED ORANGE TO DENOTE NICKEL MATERIAL

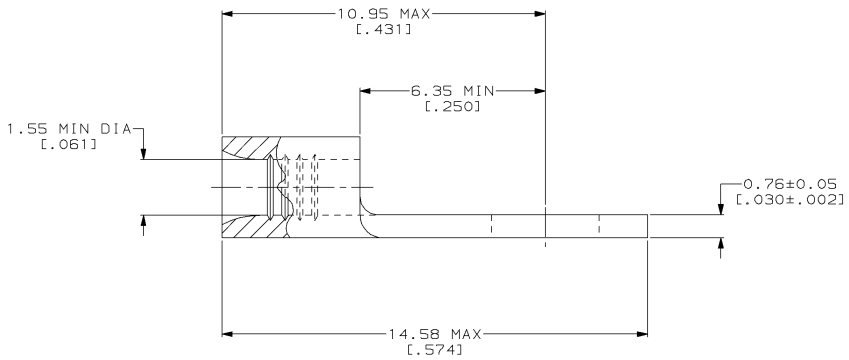
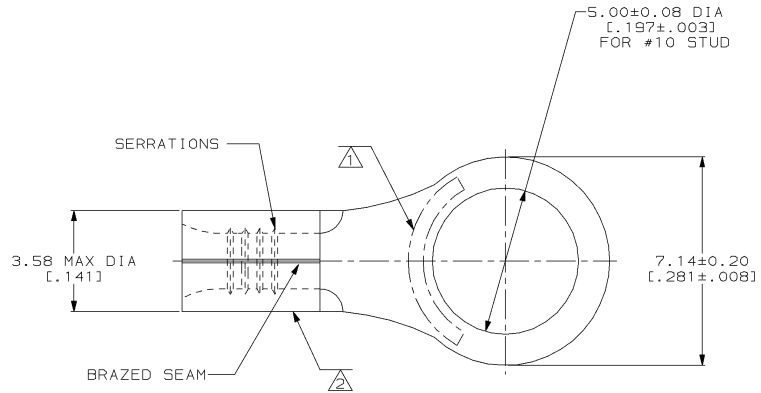

100	LOOSE PIECE, BOX	8-321891-1
----	LOOSE PIECE	321891
QUANTITY	PACKAGE TYPE	PART NO

AMP INCORPORATED
CUSTOMER SERVICE SYSTEMS

FOR ADDITIONAL PRODUCT INFORMATION OR COPIES OF DRAWINGS AND TECHNICAL DOCUMENTS

PRODUCT INFORMATION CENTER
1-800-522-6752

FOR APPLICATION TOOLING INFORMATION

TOOLING ASSISTANCE CENTER
1-800-722-1111

FOR ORDER ENTRY

1-800-526-5142

MAX RECOMMENDED OPERATING TEMPERATURE:
649°C MAX

VOLTAGE RATING:
NOT APPLICABLE

WIRE CROSS SECTIONAL AREA RANGE:
0.26-1.65mm² [509-3,260] CIR MILS
SOLID OR STRANDED

THIS DRAWING IS A CONTROLLED DOCUMENT FOR AMP INCORPORATED. IT IS SUBJECT TO CHANGE AND THE CONTROLLING ENGINEERING ORGANIZATION SHOULD BE CONTACTED FOR THE LATEST REVISION.

DO NOT SCALE PRINT.
 UNLESS SPECIFIED DIMENSIONS IN [mm] [INCHES]
 TOLERANCES ON:
 2 PLC DEC ± -
 3 PLC DEC ± -
 ANGLES ± -

MATERIAL
 NICKEL PER ASTM B-162 ANNEALED

FINISH
 -

DR 4-15-93
TA BRINKMAN

CHK 4-15-93
DA PATTERSON

APPD 4-15-93
DE MILLER

APPD 4-15-93
JL MECKLEY

PRODUCT SPEC
 -

APPLICATION SPEC
 -

WEIGHT
 -

AMP AMP Incorporated
 Harrisburg, PA 17105-3608

NAME
TERMINAL, RING TONGUE, HIGH TEMPERATURE, STRATO-THERM™

SIZE
 © 00779

CAGE CODE
 ©-321891

DRAWING NO
 ©-321891

SCALE 10:1

SHEET 1 OF 1