

THIS DRAWING IS UNPUBLISHED. RELEASED FOR PUBLICATION .19
 © COPYRIGHT 19 BY AMP INCORPORATED. ALL INTERNATIONAL RIGHTS RESERVED.

LOC	DIST	P	F	ZONE	LTR	REVISIONS	DATE	APPR
6	14					6 ADDED 2-4 PER 063A-0037-02	04FEB02	JR/MS

METRIC
 DIMENSIONS LISTED IN mm [INCHES]

AMP WIRE RANGE	UL E13288 Listed
16-14 AWG SOLID OR STRANDED	NOT APPLICABLE
LR7189 Certified	MILITARY P/N AND CLASS
NOT APPLICABLE	NOT APPLICABLE

- STAMP AMP 16-14 APPROX AS SHOWN
- WIRE BARREL COLOR CODED ORANGE TO DENOTE NICKEL MATERIAL
- PRE-PRODUCTION - FASR REQ

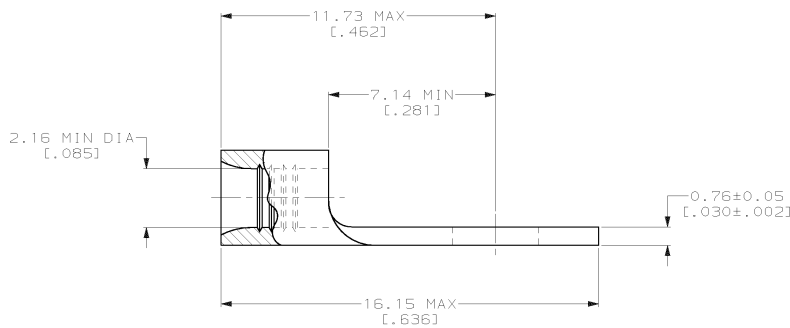
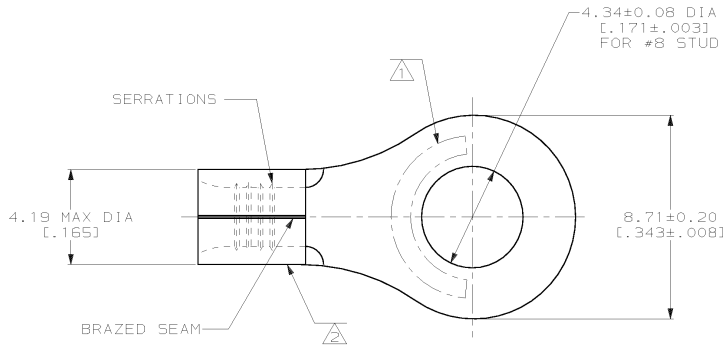

100	LOOSE PIECE, BOX	8-322334-1
5,000	ON TAPE, REEL	2-322334-4
---	LOOSE PIECE	322334
QUANTITY	PACKAGE TYPE	PART NO

AMP INCORPORATED CUSTOMER SERVICE SYSTEMS		MAX RECOMMENDED OPERATING TEMPERATURE: 649°C MAX	DO NOT SCALE PRINT. UNLESS SPECIFIED DIMENSIONS IN mm (INCHES) TOLERANCES ON: 2 PLC DEC ± - 3 PLC DEC ± - ANGLES ± -	DR 4-15-93 TA BRINKMAN CHK 4-15-93 DA PATTERSON APPD 4-15-93 DE MILLER APPD 4-15-93 JL MECKLEY	AMP AMP Incorporated Harrisburg, PA 17105-3608
FOR ADDITIONAL PRODUCT INFORMATION OR COPIES OF DRAWINGS AND TECHNICAL DOCUMENTS	PRODUCT INFORMATION CENTER 1-800-522-6752	VOLTAGE RATING: NOT APPLICABLE	MATERIAL NICKEL PER ASTM B-162 ANNEALED	PRODUCT SPEC -	
FOR APPLICATION TOOLING INFORMATION	TOOLING ASSISTANCE CENTER 1-800-722-1111	WIRE CROSS SECTIONAL AREA RANGE: 1.04-2.62mm² [2,050-5,180] CIR MILS SOLID OR STRANDED	FINISH -	APPLICATION SPEC -	NAME TERMINAL, RING TONGUE, HIGH TEMPERATURE, STRATO-THERM
FOR ORDER ENTRY	1-800-526-5142	THIS DRAWING IS A CONTROLLED DOCUMENT FOR AMP INCORPORATED. IT IS SUBJECT TO CHANGE AND THE CONTROLLING ENGINEERING ORGANIZATION SHOULD BE CONTACTED FOR THE LATEST REVISION.		WEIGHT -	SIZE CAGE CODE DRAWING NO C 00779 C-322334
					SCALE 8:1 SHEET 1 OF 1

CUSTOMER DRAWING

322334