

4

3

2

1

THIS DRAWING IS UNPUBLISHED. RELEASED FOR PUBLICATION
 © COPYRIGHT 19 BY AMP INCORPORATED. ALL RIGHTS RESERVED.

LOC	DIST	REVISIONS					
		P	LTR	DESCRIPTION	DATE	DWN	APVD
G	14	C		REV / 0720-0967-96	09SEP96	ME	TM

AMP WIRE RANGE	E13288	LR7189 Certified
12-10 AWG SOLID OR STRANDED	12-10 AWG SOLID OR STRANDED	12-10 AWG SOLID OR STRANDED

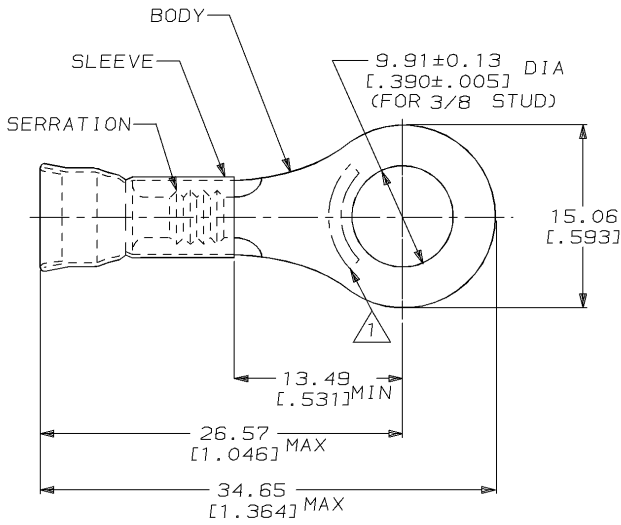

1. STAMP AMP 12-10* LOCATE APPROX AS SHOWN

- 2. WIRE INSUL DIA, 3.81-5.84 [0.150-.230]
- 3. TONGUE MATL THK, 1.02±0.05 [0.040±.002]

500	LOOSE PIECE	31828
QTY	PACKAGE TYPE	PART NO

AMP INCORPORATED CUSTOMER SERVICE SYSTEM		MAX RECOMMENDED OPERATING TEMPERATURE: 170°C [338°F]	THIS DRAWING IS A CONTROLLED DOCUMENT FOR AMP INCORPORATED. IT IS SUBJECT TO CHANGE AND THE CONTROLLING ENGINEERING ORGANIZATION SHOULD BE CONTACTED FOR THE LATEST REVISION.		DWN L OLMEDA 23JAN95	AMP AMP Incorporated Harrisburg, PA 17105-3608
FOR ADDITIONAL PRODUCT INFORMATION OR COPIES OF DRAWINGS AND TECHNICAL DOCUMENTS	PRODUCT INFORMATION CENTER 1-800-522-6752	VOLTAGE RATING: -	DIMENSIONS: mm [in]	TOLERANCES UNLESS OTHERWISE SPECIFIED: 0 PLC ±- 1 PLC ±- 2 PLC ±0.20 (0.008) 3 PLC ±- 4 PLC ±- ANGLES ±-	CHK M ELLIS 23JAN95	
FOR APPLICATION TOOLING INFORMATION	TOOLING ASSISTANCE CENTER 1-800-722-1111	CIRCULAR MIL AREA: 2.62mm²-6.64mm² [5180-13100]	MATERIAL BODY, CU, SLV, CU PER ASTM B152	FINISH TIN PLATE PER MIL-T-10727	APVD S BORTNER 23JAN95	PRODUCT SPEC UL486A
FOR ORDER ENTRY	1-800-526-5142				APPLICATION SPEC	WEIGHT -
AMP 1470-19 REV 09MAY94						SIZE A3
09 SEP 1996 14:30:21 AMP10390 <UJ28A>DEPT1132>U.DWG1132>U.RBY>U.DIAMOND-GRIP>U.CUST						CAGE CODE 00779
						DRAWING NO C-31828
						CUSTOMER DRAWING
						SCALE 4:1
						SHEET 1 OF 1
						REV C