

DRAWING MADE IN AMERICAN PROJECTION

© 1967 BY AMP INCORPORATED. ALL RIGHTS RESERVED. AMP PRODUCTS COVERED BY PATENTS AND/OR PATENTS PENDING.

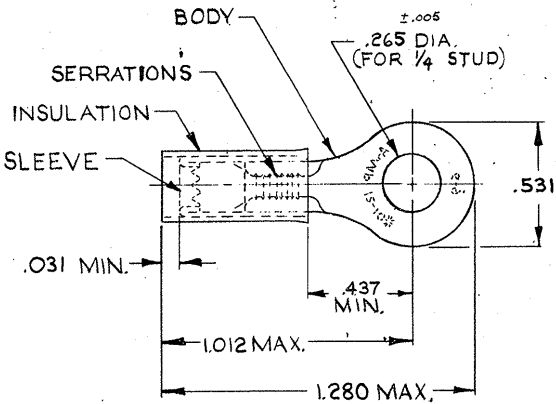

FOR .102 TO .214 WIRE INSULATION DIA.  
TONGUE MATERIAL THK. = .040 ±.002

REVISIONS

ZONE	LTR	DESCRIPTION	DATE	APPROVED
	B	REDRAWN & REV. P.6077 SR	7-30-69	FCY
	C	REVISED PC-5579 WM	10-8-70	Phu
	D	REVISED PC-5578 TR	2-23-77	L.D.
	E	REV/0610-0094-98	2-4-99	ME/ST
	E1	REV P&L ECR 05-013140	10/22/05	KW/TM

1	WIRE TERMINAL	50846	BODY: COPPER (ASTM B152) NICKEL PLATE (QQ-N-290) .0003 AVG EXT THK.
			SLEEVE: COPPER (ASTM B152) NICKEL PL(QQ-N-290).00003 AVG. EXT. THK.
			INSULATION: TEFLON (ASTM D3292) COLOR: BLACK
QTY	DESCRIPTION	PART NO.	MATERIAL & FINISH
UNLESS OTHERWISE SPECIFIED DIMENSIONS ARE IN INCHES TOLERANCES ON: DECIMALS ± .008 ANGLES ± 5°		CONTRACT NO. 4	AMP INCORPORATED HARRISBURG, PENNSYLVANIA
MATERIAL		DR. <i>W. J. Smith</i> 7-29-69 CHK. <i>P. C. Gandy</i> APPD. <i>W. J. Smith</i> 8-6-69 REL. <i>W. J. Smith</i> 8-6-69 DSGN APPD. <i>W. J. Smith</i> OTHER APPD.	
SEE TABLE			SIZE B CODE IDENT NO. 00779 NUMBER 50846
			SCALE NTS SHEET 1 OF 1