

4

3

2

1

THIS DRAWING IS UNPUBLISHED. RELEASED FOR PUBLICATION  
 © COPYRIGHT 19 BY AMP INCORPORATED. ALL RIGHTS RESERVED.

LOC	DIST	REVISIONS			
P	LTR	DESCRIPTION	DATE	DWN	APVD
G	14	J	REDRAWN PER 0720-0377-94	100CT94	LO ME

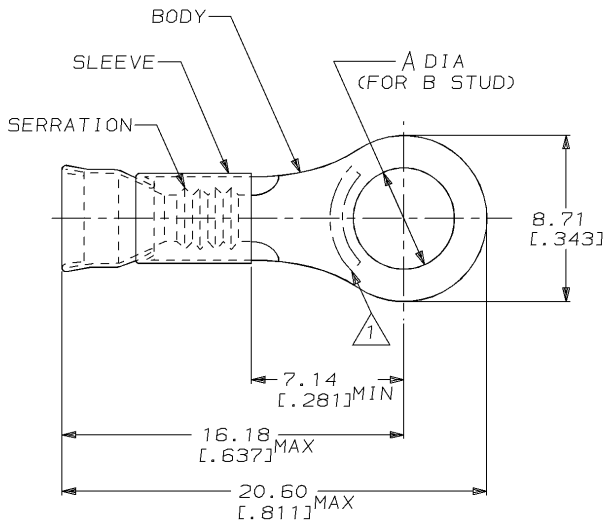

△ SEE TABLE FOR STAMPING

2. WIRE INSUL DIA, 3.05-4.32 [.120-.170]
3. TONGUE MATL THK, 0.79±0.05 [.031±.002]

AMP	WIRE DIA	WIRE THK	WIRE TYPE	SLV COLOR	QTY	PACKAGE TYPE	PART NO
AMP 16-14	4.34 ±0.08 [.171 ±.003]	#8	NICKEL PER ASTM B162	ORANGE	5000	ON TAPE, REEL	1-322337-2
AMP 16-14CH	5.00 ±0.08 [.197 ±.003]	#10	CHROMEL	GRAY	500	LOOSE PIECE	1-322337-1
AMP 16-14CH	4.34 ±0.08 [.171 ±.003]	#8	CHROMEL	GRAY	500	LOOSE PIECE	1-322337-0
AMP 16-14	4.34 ±0.08 [.171 ±.003]	#8	NICKEL PER ASTM B162	ORANGE	1000	LOOSE PIECE	322337

AMP INCORPORATED CUSTOMER SERVICE SYSTEM		MAX RECOMMENDED OPERATING TEMPERATURE: 649°C [1200°F]	VOLTAGE RATING: -	CIRCULAR MIL AREA: 1.04mm <sup>2</sup> -2.62mm <sup>2</sup> [2050-5180]	STRANDED WIRE	DIMENSIONS: mm [in]	TOLERANCES UNLESS OTHERWISE SPECIFIED: 0 PLC ±- 1 PLC ±- 2 PLC ±0.20 (.008) 3 PLC ±- 4 PLC ±- ANGLES ±-	FINISH: SLV COLOR, SEE TABLE	DWN L OLMEDA 100CT94	CHK M ELLIS 100CT94	APVD S BORTNER 100CT94	NAME AMP Incorporated Harrisburg, PA 17105-3608	PRODUCT SPEC	APPLICATION SPEC	WEIGHT	SIZE A3	CAGE CODE 00779	DRAWING NO C-322337	CUSTOMER DRAWING	SCALE 6:1	SHEET 1 OF 1	REV J
FOR ADDITIONAL PRODUCT INFORMATION OR COPIES OF DRAWINGS AND TECHNICAL DOCUMENTS	PRODUCT INFORMATION CENTER 1-800-522-6752																					
FOR APPLICATION TOOLING INFORMATION	TOOLING ASSISTANCE CENTER 1-800-722-1111																					
FOR ORDER ENTRY	1-800-526-5142																					

AMP 1470-19 REV 09MAY94

31 OCT 1994 14:59:12 AMP12360 &lt;UJ128A&gt;DEPT1132-U,DWG1132-U, RBY-U, DIAMOND-GRIP-U, STRATOTHERM-U, CUST