

THIS DRAWING IS UNPUBLISHED. RELEASED FOR PUBLICATION
 © COPYRIGHT 19 BY AMP INCORPORATED. ALL INTERNATIONAL RIGHTS RESERVED.

LOC	DIST	P	F	ZONE	LTR	DESCRIPTION	DATE	APPD
G	14				J	REV, RDRW, & SM PKG PER 0720-0061-93	4-16-93	APD

METRIC
 DIMENSIONS LISTED IN mm [INCHES]

AMP WIRE RANGE	E13288 Listed
12-10 AWG SOLID OR STRANDED	NOT APPLICABLE
LR7189 Certified	MILITARY P/N AND CLASS
NOT APPLICABLE	NOT APPLICABLE

- STAMP AMP 12-10 APPROX AS SHOWN
- WIRE BARREL COLOR CODED ORANGE TO DENOTE NICKEL MATERIAL

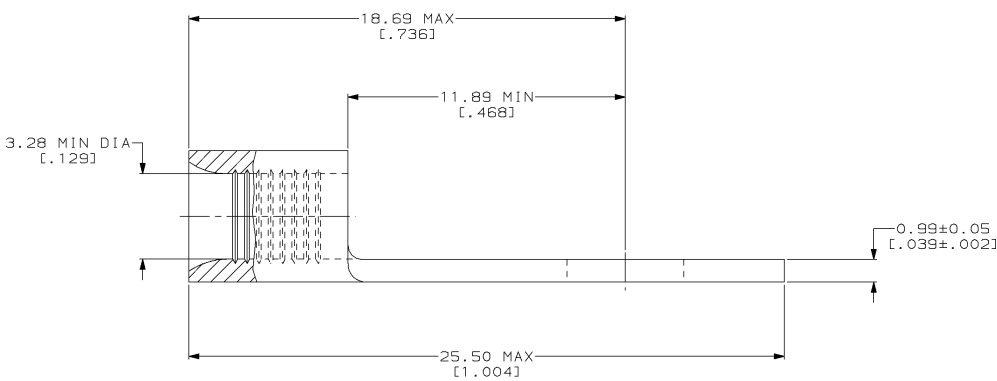
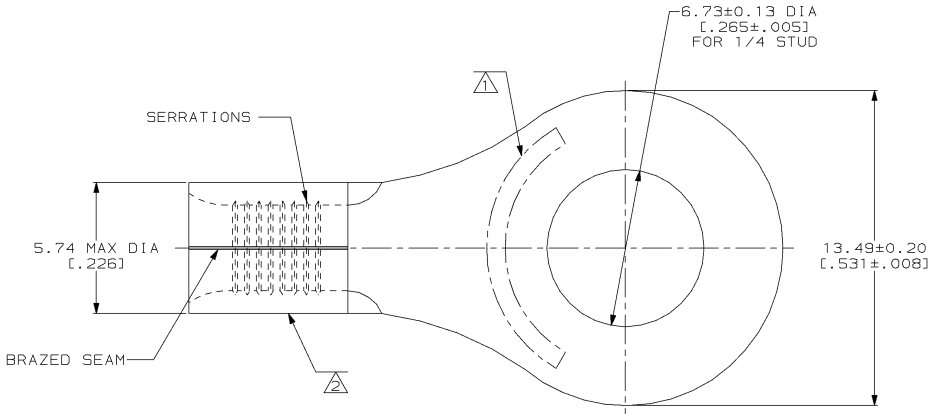

50	LOOSE PIECE, BOX	8-323683-2
2500	ON TAPE	2-323683-2
---	LOOSE PIECE	323683
QUANTITY	PACKAGING TYPE	PART NO

AMP INCORPORATED
 CUSTOMER SERVICE SYSTEMS

MAX RECOMMENDED OPERATING TEMPERATURE:
 649°C MAX

DO NOT SCALE PRINT.
 UNLESS SPECIFIED DIMENSIONS IN mm [INCHES]
 TOLERANCES ON:
 2 PLC DEC ± -
 3 PLC DEC ± -
 ANGLES ± -

DR 4-16-93
 TA BRINKMAN
 CHK 4-16-93
 DA PATTERSON
 APPD 4-16-93
 DE MILLER
 APPD 4-16-93
 JL MECKLEY
 PRODUCT SPEC

AMP AMP Incorporated
 Harrisburg, PA 17105-3608

FOR ADDITIONAL PRODUCT INFORMATION OR COPIES OF DRAWINGS AND TECHNICAL DOCUMENTS

PRODUCT INFORMATION CENTER
 1-800-522-6752

VOLTAGE RATING:
 NOT APPLICABLE

MATERIAL
 NICKEL PER ASTM B-162 ANNEALED

FINISH
 -

NAME
 TERMINAL, RING TONGUE,
 HIGH TEMPERATURE,
 STRATO-THERM™

FOR APPLICATION TOOLING INFORMATION

TOOLING ASSISTANCE CENTER
 1-800-722-1111

WIRE CROSS SECTIONAL AREA RANGE:
 2.62-6.64mm² [5,180-13,100] CIR MILS
 SOLID OR STRANDED

THIS DRAWING IS A CONTROLLED DOCUMENT FOR AMP INCORPORATED. IT IS SUBJECT TO CHANGE AND THE CONTROLLING ENGINEERING ORGANIZATION SHOULD BE CONTACTED FOR THE LATEST REVISION.

APPLICATION SPEC
 -

SIZE
 00779
 DRAWING NO
 323683

FOR ORDER ENTRY

1-800-526-5142

WEIGHT
 -

SCALE 8:1
 SHEET 1 OF 1