

4

3

2

1

THIS DRAWING IS UNPUBLISHED. RELEASED FOR PUBLICATION
 © COPYRIGHT - BY TYCO ELECTRONICS CORPORATION. ALL RIGHTS RESERVED.

LOC	DIST	REVISIONS			
P	LTR	DESCRIPTION	DATE	DWN	APVD
G	14				
	C1	REV PER ECR 09-026074	30NOV09	JR	TM

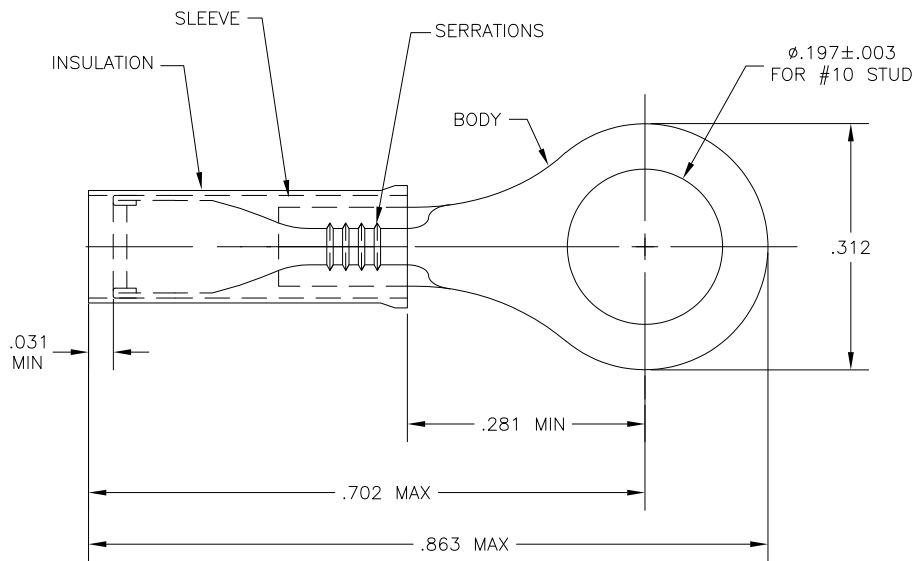

- 1 TONGUE MATERIAL THK IS .027±.001
- 2 FOR .050 TO .105 WIRE INS. DIA.
- 3 MUST BE CRIMPED WITH 22-18 OR 22-16 PIDG (RED) TOOL.

- △4 MEETS MS25036-147, CLASS 1 & 2
 △5 MEETS MS25036-147, CLASS 2

2500	DN TAPE, REEL	△5 54312-2	BODY: COPPER ASTM B152 TIN PL PER ASTM B545
1000	LOOSE PIECE	△4 54312-1	SLEEVE: COPPER ASTM B152 TIN PL PER ASTM B545
QTY	PACKAGE TYPE	PART NO	INSULATION: NYLON, COLOR: YELLOW
			MATERIAL & FINISH

DIMENSIONS:		TOLERANCES UNLESS OTHERWISE SPECIFIED:		DWN		27JAN04		Tyco Electronics		Tyco Electronics Corporation	
INCHES		0 PLC	± -	JR RUTH		27JAN04		Harrisburg, Pa 17105-3608		NAME	
		1 PLC	± -	T MICHELUTTI		27JAN04		PRODUCT SPEC		TERMINAL, NYLON PIDG, RING TONGUE; WIRE SIZE 26-24	
MATERIAL		2 PLC	± -	T MICHELUTTI		27JAN04		APPLICATION SPEC		RESTRICTED TO	
SEE TABLE		3 PLC	± .008	APVD		NAME		SIZE		CAGE CODE	
FINISH		4 PLC	± -	WEIGHT		DRAWING NO		A3		00779	
SEE TABLE		ANGLES	± 1°	CUSTOMER DRAWING		C-54312		SCALE		8:1	
								SHEET		1 OF 1	
								REV		C1	