

4

3

2

1

THIS DRAWING IS UNPUBLISHED. RELEASED FOR PUBLICATION .19
 © COPYRIGHT 19 BY AMP INCORPORATED. ALL RIGHTS RESERVED.

LOC	DIST	REVISIONS			
P	LTR	DESCRIPTION	DATE	DWN	APVD
G	14	F	REV PER 063A-0331-02	26AUG02	JR TM

AMP WIRE RANGE	E13288	LR7189 Certified
12-10 AWG SOLID OR STRANDED	12-10 AWG SOLID OR STRANDED	12-10 AWG SOLID OR STRANDED

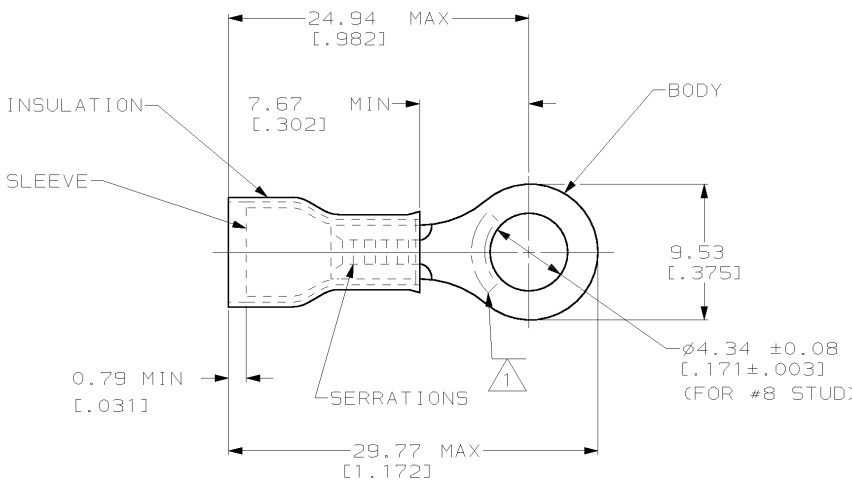

- 1. STAMP AMP 12-10* APPROX A5 SHOWN
- 2. WIRE INSUL DIA, 4.32-7.62 [0.170-.300]
- 3. TONGUE MATERIAL THK, 1.02±0.05 [0.040±.002]

---	-----	-----
50	LOOSE PIECE, BOX	8-35605-2
1500	ON TAPE, REEL	2-35605-2
500	LOOSE PIECE	35605
QTY	PACKAGE TYPE	PART NO

AMP INCORPORATED CUSTOMER SERVICE SYSTEM		MAX RECOMMENDED OPERATING TEMPERATURE: 105° C [221° F]	THIS DRAWING IS A CONTROLLED DOCUMENT FOR AMP INCORPORATED. IT IS SUBJECT TO CHANGE AND THE CONTROLLING ENGINEERING ORGANIZATION SHOULD BE CONTACTED FOR THE LATEST REVISION.		DWN M ELLIS 17APR95	AMP Incorporated Harrisburg, PA 17105-3608
FOR ADDITIONAL PRODUCT INFORMATION OR COPIES OF DRAWINGS AND TECHNICAL DOCUMENTS	PRODUCT INFORMATION CENTER 1-800-522-6752	VOLTAGE RATING: - 300V MAX	DIMENSIONS: mm [in]	TOLERANCES UNLESS OTHERWISE SPECIFIED: 0 PLC ±- 1 PLC ±- 2 PLC ±0.20 [0.008] 3 PLC ±- 4 PLC ±- ANGLES ±-	CHK C PRESNELL 17APR95	
FOR APPLICATION TOOLING INFORMATION	TOOLING ASSISTANCE CENTER 1-800-722-1111	CIRCULAR MIL AREA: 2.63mm ² -6.64mm ² (5180-13100)		FINISH BODY & SLV, TIN PLATE PER MIL-T-10727	APVD N BIRCH 17APR95	PRODUCT SPEC UL 486A
FOR ORDER ENTRY	1-800-526-5142		MATERIAL BODY, SLV, COPPER PER ASTH B 152 INSUL, PVC, COLOR, YELLOW	WEIGHT -	APPLICATION SPEC -	SIZE A3
AMP 1470-19 REV 09MAY94					CUSTOMER DRAWING	CAGE CODE 00779
24 AUG 1995 11:00:52 AMP10398 <U128A>DEPT1132-U.DWG1132-U.RBY-U.PID6-U.CUST						DRAWING NO C-35605
						SCALE 4:1
						SHEET 1 OF 1
						REV F