

THE DRAWING IS UNPUBLISHED. RELEASED FOR PUBLICATION. ALL RIGHTS RESERVED.

LOC	REV	DESCRIPTION	DATE	BY	APP
G	14	H1 REVISED PER ECO-11-004820	11MAR11	RK	HMR



AMP WIRE RANGE	E13288 Listed
8 AWG SOLID OR STRANDED	8 AWG STRANDED
LR7189 Certified	MILITARY P/N AND CLASS
8 AWG SOLID OR STRANDED	NOT APPLICABLE

△ STAMP AMP 8* APPROX AS SHOWN

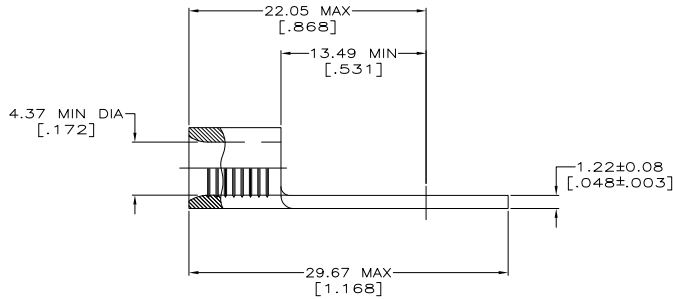
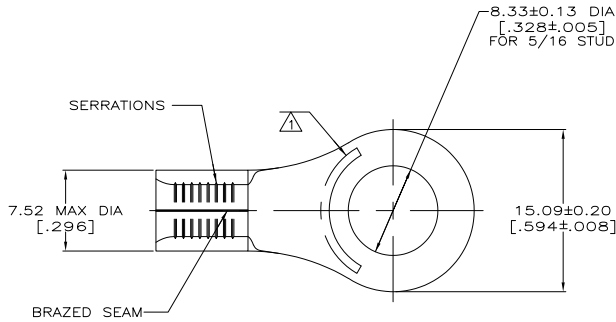

AMP INCORPORATED CUSTOMER SERVICE SYSTEMS		MAX RECOMMENDED OPERATING TEMPERATURE: 170° C MAX
FOR ADDITIONAL PRODUCT INFORMATION OR COPIES OF DRAWINGS AND TECHNICAL DOCUMENTS	PRODUCT INFORMATION CENTER 1-800-522-6752	VOLTAGE RATING: NOT APPLICABLE
FOR APPLICATION TOOLING INFORMATION	TOOLING ASSISTANCE CENTER 1-800-722-1111	WIRE CROSS SECTIONAL AREA RANGE: 6.64-10.5mm ² [13,100-20,800] CIR MILS SOLID OR STRANDED
FOR ORDER ENTRY	1-800-526-5142	THIS DRAWING IS A CONTROLLED DOCUMENT FOR AMP INCORPORATED. IT IS SUBJECT TO CHANGE AND THE CONTROLLING ENGINEERING ORGANIZATION SHOULD BE CONTACTED FOR THE LATEST REVISION.

SUPERSEDED BY 8-33462-1	25	LOOSE PIECE, BAG	8-33462-5
	100	LOOSE PIECE, BOX	8-33462-1
	1500	MOUNTED ON TAPE, REEL	2-33462-1
	1000	LOOSE PIECE, BOX	33462-1
	-	LOOSE PIECE	33462
QTY		PACKAGE TYPE	PART NO

THIS DRAWING IS A CONTROLLED DOCUMENT.		PREPARED BY TA BRINKMAN 3-24-93	TE Connectivity
DRAWN BY DA PATTERSON 3-24-93		APPROVED BY DE MILLER 3-24-93	
DIMENSIONS: mm [INCHES]	TOLERANCES UNLESS OTHERWISE SPECIFIED:	PRODUCT SPEC	TERMINAL, RING TONGUE, SOLISTRAND TM
	0 PUC ± .005 1 PUC ± .005 2 PUC ± .005 3 PUC ± .005 4 PUC ± .005 ANGLES ± .005	APPLICATION SPEC	SIZE A2
MATERIAL: COPPER PER ASTM B-152 ANNEALED	FINISH: TIN PLATE 0.0025(00100) MIN TW PER MIL-1-10727	WEIGHT	DRAWING NO 00779
CUSTOMER DRAWING		SCALE	4:1
		SHEET	1 of 1
		REV	H1

1471-9 (3/11)

33462