

DRAWING MADE IN AMERICAN PROJECTION

© 1954 BY AMP INCORPORATED. ALL RIGHTS RESERVED. AMP PRODUCTS COVERED BY PATENTS AND/OR PATENTS PENDING.

REVISIONS				
ZONE	LTR	DESCRIPTION	DATE	APPROVED
C		REDRAWN, REV ADDED TAPE NO'S P-6080	5-13-70	<i>me</i>
D		INACTIVE ECN P-6740	REV 2-27-72	<i>BB</i>
E		2-3 INACTIVE PER P. 7260	dc 11/10/82	<i>me</i>
F		ORs 2-3 REV. G2591	BT 10-19-87	<i>PMF</i>
G		REV PER G-4732	JT 7/27/88	<i>BT</i>
H		REV/0720=0036-93	TQ 3-5-93	<i>me</i>
J		REV/0220-0273-97	TM 1-12-98	<i>me</i>

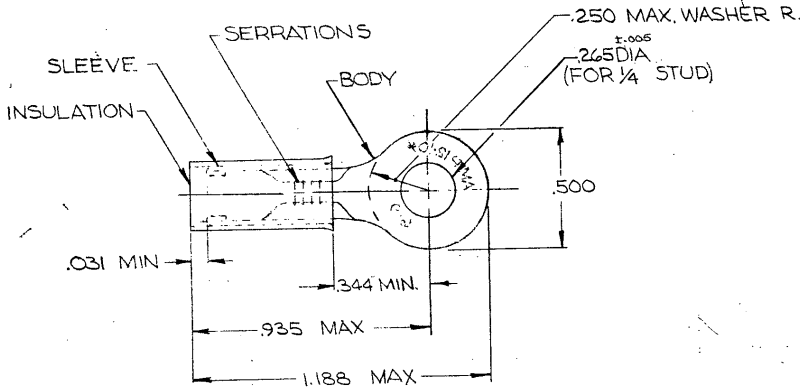

FOR .150 TO .230 INSULATION DIA.
TONGUE MATERIAL .THK = .040 ±.002

OBSOLETE
INACTIVE ①

QTY	DESCRIPTION	PART NO.	MATERIAL & FINISH
50	LOOSE PC. BOX	8-35273-2	INSULATION, SLEEVE, AND BODY: SAME AS 35273
1	2-35273-4 ON TAPE	2-35273-3	INSULATION: GREEN PVC
1	WIRE TERMINAL	2-35273-1	SLEEVE: COPPER (ASTM B152) BODY: COPPER (ASTM B152) TIN PL (ASTM B545)
1	35273 ON TAPE	2-35273-2	INSULATION: YELLOW NYLON SLEEVE: COPPER (ASTM B152)
1	WIRE TERMINAL	35273	BODY: COPPER (ASTM B152) TIN PL (ASTM B545)

UNLESS OTHERWISE SPECIFIED, DIMENSIONS ARE IN INCHES TOLERANCES ON: DECIMALS ±.008 ANGLES 1°	CONTRACT NO.	AMP INCORPORATED HARRISBURG, PENNSYLVANIA	
	DR. <i>W. Miller</i> 4-23-70	NAME	WIRE TERMINAL P.I.D.G. - RING TONGUE WIRE SIZE :12-10
MATERIAL SEE TABLE	CHK. <i>M. Ensign</i> 5-18-70	SIZE	B 00779
	APPD. <i>W. Miller</i> 5-18-70	NUMBER	35273
REL. <i>A. Long</i> 5-17-70	DSGN APPD.	SCALE	NTS
OTHER APPD.		SHEET	1 OF 1

CUSTOMER DRAWING