

REV	DATE	DESCRIPTION	BY	APP'D
1				
2				
3				
4				

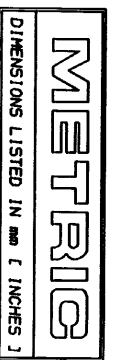

<b>AMP</b> WIRE RANGE	<b>UL</b> E13288 Listed
12-10 AWG STRANDED	12-10 AWG STRANDED
<b>LR7189</b> Certified	MILITARY P/N AND CLASS
NOT CERTIFIED	NOT APPLICABLE

△ STAMP AMP 12-10\* APPROX AS SHOWN

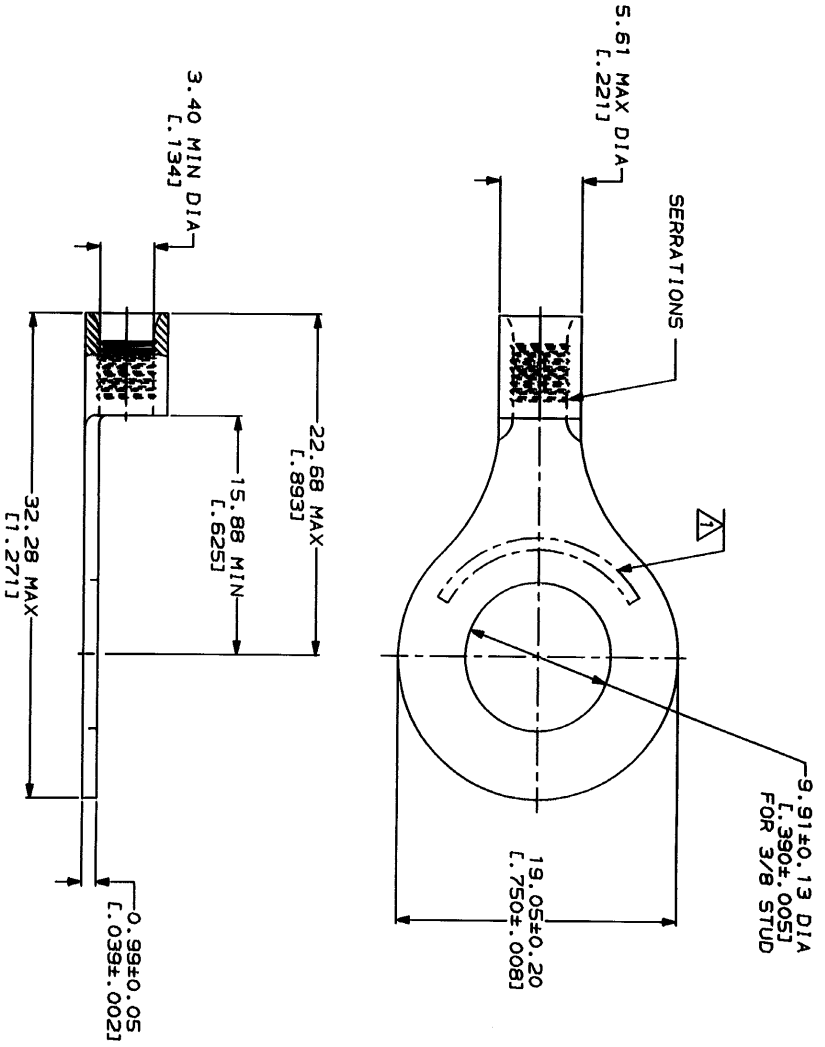

**AMP INCORPORATED  
CUSTOMER SERVICE SYSTEMS**

FOR ADDITIONAL  
PRODUCT INFORMATION OR  
COPIES OF DRAWINGS  
AND TECHNICAL DOCUMENTS  
FOR APPLICATION  
TOOLING INFORMATION  
FOR ORDER ENTRY

PRODUCT INFORMATION CENTER  
1-800-522-6752

TOOLING ASSISTANCE CENTER  
1-800-722-1111

1-800-526-5142

MAX RECOMMENDED OPERATING  
TEMPERATURE:  
170°C MAX

VOLTAGE RATING:  
NOT APPLICABLE

WIRE CROSS SECTIONAL AREA RANGE:  
2.62-6.64mm<sup>2</sup> [5.180-13.100] CIR MILS  
STRANDED

FINISH: TIN PLATE  
0.00254 [L.000100] MIN  
THK PER MIL-T-10727

DO NOT SCALE PRINT.  
UNLESS SPECIFIED  
DIMENSIONS IN  
TOLERANCES ON  
P/LC DEC ±  
ANGLES ±

DR 2-9-93  
TA BRINKMAN  
CHK 2-9-93  
DA PATTERSON  
APPD 2-9-93  
DE MILLER  
APPD 2-9-93  
JL WICKLEY  
PRODUCT SPEC

APPLICATION SPEC

**AMP**  
AMP Incorporated  
Hornbush, PA 17105-3608

34833 PART NO

TERMINAL, RING TONGUE,  
BUDGET

SIZE CASE CODE DRAWING NO  
00779 34833

SCALE 4:1 SHEET 1 OF 1