

4

3

2

1

THIS DRAWING IS UNPUBLISHED. RELEASED FOR PUBLICATION
 © COPYRIGHT 19 BY AMP INCORPORATED. ALL RIGHTS RESERVED.

LOC	DIST	REVISIONS			
P	LTR	DESCRIPTION	DATE	DWN	APVD
G	14	E	REDRAWN PER 0720-0470-95	23JAN95	LO ME

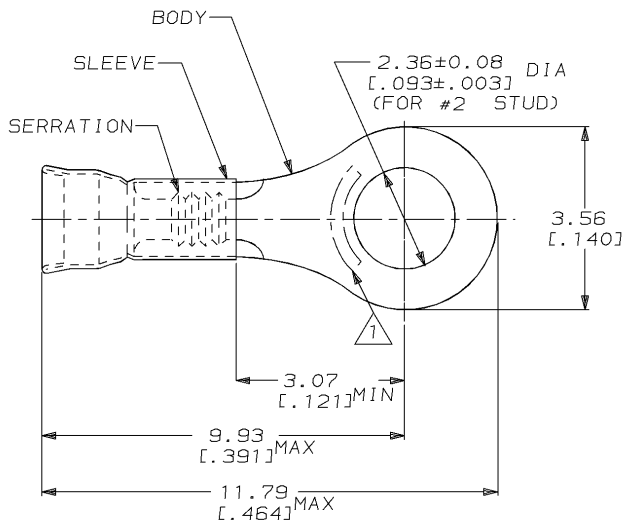

△ STAMP AMP LOCATE APPROX AS SHOWN

2. WIRE INSUL DIA, 1.27-2.08 [0.050-.082]
3. TONGUE MATL THK, 0.46±0.05 [0.018±.002]

5000	ON TAPE, REEL	2-31518-1
1000	LOOSE PIECE	31518
QTY	PACKAGE TYPE	PART NO

AMP INCORPORATED CUSTOMER SERVICE SYSTEM		MAX RECOMMENDED OPERATING TEMPERATURE: -	THIS DRAWING IS A CONTROLLED DOCUMENT FOR AMP INCORPORATED. IT IS SUBJECT TO CHANGE AND THE CONTROLLING ENGINEERING ORGANIZATION SHOULD BE CONTACTED FOR THE LATEST REVISION.		DWN L OLMEDA 23JAN95	AMP Incorporated Harrisburg, PA 17105-3608
FOR ADDITIONAL PRODUCT INFORMATION OR COPIES OF DRAWINGS AND TECHNICAL DOCUMENTS	PRODUCT INFORMATION CENTER 1-800-522-6752	VOLTAGE RATING: -	DIMENSIONS: mm [in]	TOLERANCES UNLESS OTHERWISE SPECIFIED: 0 PLC ±- 1 PLC ±- 2 PLC ±0.20 [0.008] 3 PLC ±- 4 PLC ±- ANGLES ±-	CHK M ELLIS 23JAN95	
FOR APPLICATION TOOLING INFORMATION	TOOLING ASSISTANCE CENTER 1-800-722-1111	CIRCULAR MIL AREA: 0.10mm ² -0.41mm ² [202-810]	MATERIAL BODY, CU, SLV, CU PER ASTM B152	FINISH TIN PLATE PER MIL-T-10727	APVD S BORTNER 23JAN95	PRODUCT SPEC -
FOR ORDER ENTRY	1-800-526-5142	STRANDED WIRE			APPLICATION SPEC -	WEIGHT -
AMP 1470-19 REV 09MAY94						SIZE A3
						CAGE CODE 00779
						DRAWING NO C-31518
						SCALE 10:1
						SHEET 1 OF 1
						REV E

24 JAN 1995 12:32:09 AMP12360 <UJ128A>DEPT1132-U, DWG1132-U, RBY-U, DIAMOND-GRIP-U, CUST