

4

3

2

1

THIS DRAWING IS UNPUBLISHED. RELEASED FOR PUBLICATION
 © COPYRIGHT 19 BY AMP INCORPORATED. ALL RIGHTS RESERVED.

LOC	DIST	REVISIONS					
		P	LTR	DESCRIPTION	DATE	DWN	APVD
G	14	E		OBS 2--1 / OL20-0081-96	12DEC96	ME	SB

AMP WIRE RANGE	E13288	LR7189 Certified
16-14 AWG SOLID OR STRANDED	16-14 AWG SOLID OR STRANDED	16-14 AWG SOLID OR STRANDED

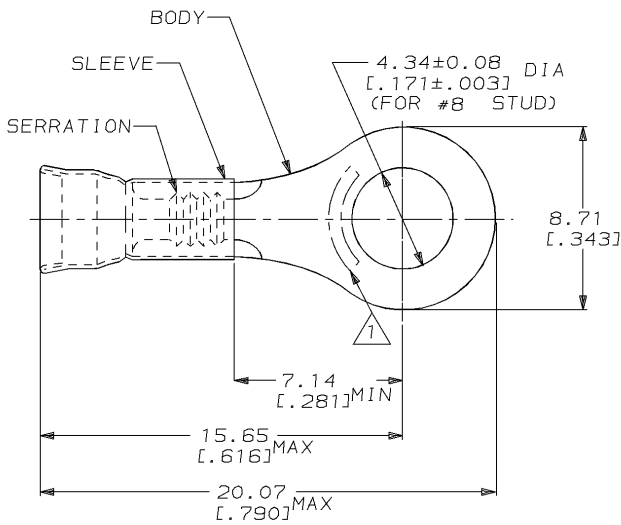

1. STAMP AMP 16-14* LOCATE APPROX AS SHOWN

2. WIRE INSUL DIA, 2.92-4.32 [0.115-.170]

3. TONGUE MATL THK, 0.79±0.05 [0.031±.002]

OBSOLETE	5000	ON TAPE, REEL	2-30927-1
	1000	LOOSE PIECE	30927
	QTY	PACKAGE TYPE	PART NO

AMP INCORPORATED CUSTOMER SERVICE SYSTEM		MAX RECOMMENDED OPERATING TEMPERATURE: 170°C [338°F]	THIS DRAWING IS A CONTROLLED DOCUMENT FOR AMP INCORPORATED. IT IS SUBJECT TO CHANGE AND THE CONTROLLING ENGINEERING ORGANIZATION SHOULD BE CONTACTED FOR THE LATEST REVISION.		DWN L OLMEDA 23JAN95	AMP AMP Incorporated Harrisburg, PA 17105-3608
FOR ADDITIONAL PRODUCT INFORMATION OR COPIES OF DRAWINGS AND TECHNICAL DOCUMENTS	PRODUCT INFORMATION CENTER 1-800-522-6752	VOLTAGE RATING: -	DIMENSIONS: mm [in]	TOLERANCES UNLESS OTHERWISE SPECIFIED: 0 PLC ±- 1 PLC ±- 2 PLC ±0.20 (0.008) 3 PLC ±- 4 PLC ±- ANGLES ±-	CHK M ELLIS 23JAN95	
FOR APPLICATION TOOLING INFORMATION	TOOLING ASSISTANCE CENTER 1-800-722-1111	CIRCULAR MIL AREA: 1.04mm ² -2.62mm ² [2050-5180]	MATERIAL BODY, CU, SLV, CU PER ASTM B152	FINISH TIN PLATE PER MIL-T-10727	APVD S BORTNER 23JAN95	PRODUCT SPEC UL486A
FOR ORDER ENTRY	1-800-526-5142				APPLICATION SPEC	SIZE A3
					WEIGHT -	CAGE CODE 00779
					CUSTOMER DRAWING	DRAWING NO C-30927
					SCALE 6:1	SHEET 1 OF 1
					REV E	

AMP 1470-19 REV 09MAY94

12 DEC 1996 08:49:40 AMP10390 <UJ28A>DEPT1132>U.DWG1132>U.RBY>U.DIAMOND-GRIP>U.CUST