

4 3 2 1  
 DRAWING MADE IN THIRD ANGLE PROJECTION  
 THIS DRAWING IS UNPUBLISHED. RELEASED FOR PUBLICATION  
 © COPYRIGHT 19 BY AMP INCORPORATED. ALL INTERNATIONAL RIGHTS RESERVED.

LOC	DIST	ZONE	LTR	REVISIONS	DATE	APPD
G	14	P	F	B	REV & REDRAWN PER 0720-0040-93	3-17-93

**METRIC**  
 DIMENSIONS LISTED IN mm [ INCHES ]

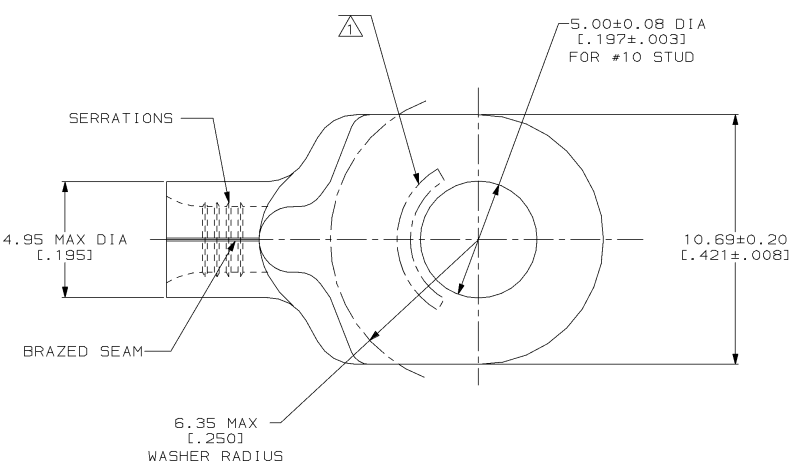

<b>AMP</b> WIRE RANGE	<b>UL</b> E13288 Listed
14-12 AWG SOLID OR STRANDED	14-12 AWG STRANDED
<b>UL</b> LR7189 Certified	MILITARY P/N AND CLASS
14-12 AWG SOLID OR STRANDED	NOT APPLICABLE

△ STAMP AMP 14-12\* APPROX AS SHOWN

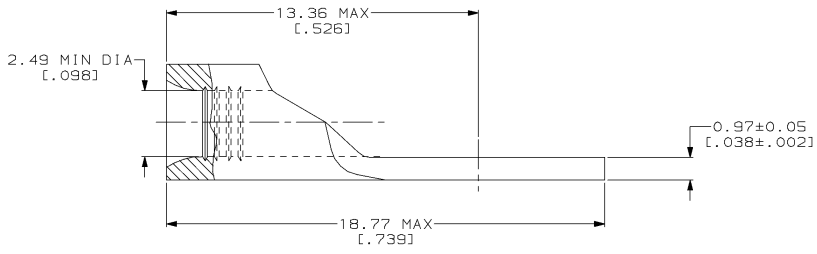

5000	ON TAPE	1-34484-0
----	LOOSE PIECE	34484
QUANTITY	PACKAGING TYPE	PART NO

**AMP INCORPORATED**  
**CUSTOMER SERVICE SYSTEMS**

FOR ADDITIONAL PRODUCT INFORMATION OR COPIES OF DRAWINGS AND TECHNICAL DOCUMENTS	PRODUCT INFORMATION CENTER 1-800-522-6752
FOR APPLICATION TOOLING INFORMATION	TOOLING ASSISTANCE CENTER 1-800-722-1111
FOR ORDER ENTRY	1-800-526-5142

MAX RECOMMENDED OPERATING TEMPERATURE:  
170°C MAX

VOLTAGE RATING:  
NOT APPLICABLE

WIRE CROSS SECTIONAL AREA RANGE:  
1.65-4.17mm<sup>2</sup> [3,260-8,230] CIR MILS  
SOLID OR STRANDED

THIS DRAWING IS A CONTROLLED DOCUMENT FOR AMP INCORPORATED. IT IS SUBJECT TO CHANGE AND THE CONTROLLING ENGINEERING ORGANIZATION SHOULD BE CONTACTED FOR THE LATEST REVISION.

DO NOT SCALE PRINT.  
 UNLESS SPECIFIED DIMENSIONS IN mm [INCHES]  
 TOLERANCES ON:  
 2 PLC DEC ± -  
 3 PLC DEC ± -  
 ANGLES ± -

MATERIAL  
 COPPER PER  
 ASTM B-152  
 ANNEALED

FINISH  
 T1N PLATE  
 0.00254 [0.00100] MIN  
 THK PER MIL-T-10727

DR 3-17-93  
TA BRINKMAN

CHK 3-17-93  
DA PATTERSON

APPD 3-17-93  
DE MILLER

APPD 3-17-93  
JL MECKLEY

PRODUCT SPEC  
-

APPLICATION SPEC  
-

WEIGHT  
-

**AMP** AMP Incorporated  
 Harrisburg, PA 17105-3608

NAME  
**TERMINAL, RING TONGUE, SOLISTRAND™**

SIZE  
 00779

DRAWING NO  
 ©-34484

SCALE 8:1

SHEET 1 OF 1

AMP 1471-6 REV 3-92  
 10\_SEP\_1993 06:41:51 AMP26463 <U5128A>DEPT1123>DWG1123>U\_SOL1STRAND>U\_INL\_INE

CUSTOMER DRAWING

34484