

4

3

2

1

THIS DRAWING IS UNPUBLISHED. RELEASED FOR PUBLICATION
 © COPYRIGHT - BY TYCO ELECTRONICS CORPORATION. ALL RIGHTS RESERVED.

LOC	DIST	REVISIONS					
		P	LTR	DESCRIPTION	DATE	DWN	APVD
G	14			REV PER 0G3A-0640-04	16AUG04	JR	TM

AMP WIRE RANGE	Listed FILE E13288	LR7189 Certified
22-16 AWG SOLID OR STRANDED	22-16 AWG SOLID OR STRANDED	22-16 AWG SOLID OR STRANDED

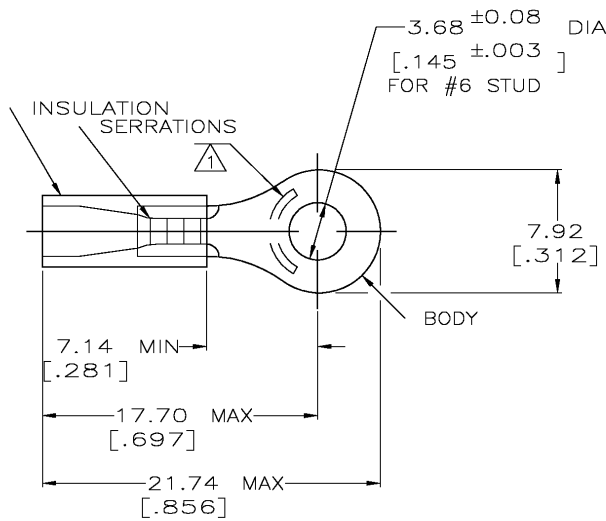

- 1 STAMP AMP 22-18* 1-2 APPROX AS SHOWN
22-16 TERMINALS ARE STAMPED 22-18 IN
ACCORDANCE WITH MILITARY SPEC MIL-T-7928
COMMERCIAL WIRE RANGE IS 22-16
- 2 WIRE INSULATION DIA: 2.03-3.18 [0.080-.125]
- 3 TONGUE MATERIAL THK: 0.79 ± 0.05 [0.031 ± 0.002]
- 4 MATERIAL: BODY - CU PER ASTM B152
SLEEVE - PVC, COLOR - RED

5000	ON TAPE, REEL	2-32950-1
1000	LOOSE PIECE	32950
QTY	PACKAGE TYPE	PART NO.

AMP INCORPORATED CUSTOMER SERVICE SYSTEMS		MAX RECOMMENDED OPERATING TEMPERATURE: 105°C [221°F]	THIS DRAWING IS A CONTROLLED DOCUMENT.		DWN DK SCHRUM 08/06/92	Tyco Electronics Corporation Harrisburg, Pa 17105-3608	
FOR ADDITIONAL PRODUCT INFORMATION OR COPIES OF DRAWINGS AND TECHNICAL DOCUMENTS	PRODUCT INFORMATION CENTER 1-800-522-6752	VOLTAGE RATING: 600V MAX (1000V FIXTURE OR SIGN)	DIMENSIONS: MM [INCHES]	TOLERANCES UNLESS OTHERWISE SPECIFIED: 0 PLC ± - 1 PLC ± - 2 PLC ± 0.20 [008] 3 PLC ± - 4 PLC ± - ANGLES ± -	CHK RE HERSEY 11/10/92		NAME M BARNABA 11/10/92
FOR APPLICATION	TOOLING ASSISTANCE CENTER 1-800-722-1111	CIRCULAR MIL AREA: 0.26-1.85mm² [509-3260] SOLID OR STRANDED		MATERIAL - 4	FINISH TIN PER ASTM B545	PRODUCT SPEC UL 486A	TERMINAL, RING TONGUE, PLASTI-GRIP, WIRE SIZE, 22-16 AWG
TOOLING INFORMATION	1-800-722-1111	THIS DRAWING IS A CONTROLLED DOCUMENT FOR AMP INCORPORATED. IT IS SUBJECT TO CHANGE AND THE CONTROLLING ENGINEERING ORGANIZATION SHOULD BE CONTACTED FOR THE LATEST REVISION.				APPLICATION SPEC -	SIZE A3
FOR ORDER ENTRY	1-800-526-5142					WEIGHT -	CAGE CODE 00779
					CUSTOMER DRAWING	DRAWING NO 32950	RESTRICTED TO -
					SCALE 4:1	SHEET 1	OF 1
					REV G		

AMP 1470-19 REV 31MAR2000