

THIS DRAWING IS UNPUBLISHED. RELEASED FOR PUBLICATION . 19
 © COPYRIGHT 19 BY AMP INCORPORATED, HARRISBURG, PA. ALL INTERNATIONAL RIGHTS RESERVED. AMP PRODUCTS MAY BE COVERED BY U.S. AND FOREIGN PATENTS AND/OR PATENTS PENDING.

REVISIONS						
P	F	ZONE	LTR	DESCRIPTION	DATE	APPROVED
✓	✓		K	REDRAWN-REVISED PER G-1479, G-1179, P67-0123 & P85-0124	2/10/84	PM
✓	✓		L	OBSELETE 2-482-5/G-2393	7/24/87	SS
✓	✓		M	OBSELETE 323011 G-2390	8/26/87	PMF/jm
✓	✓		N	REV PER G-4732	8/88	PM
✓	✓		P	REACT 323011 PER G-4856	1/1/88	PM
✓	✓		R	REV 10720-0836-95	10/29/94	PM

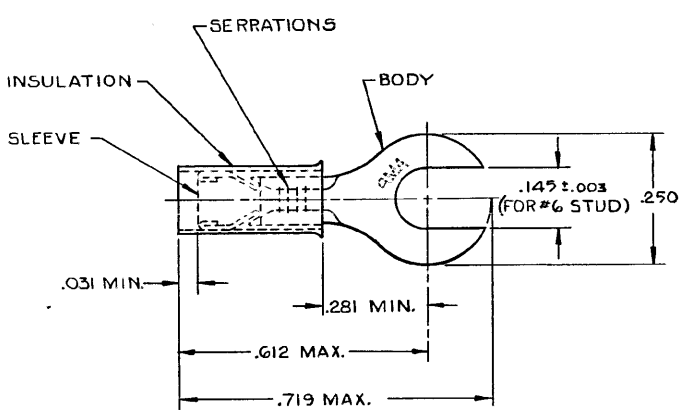

- 1 WIRE INSULATION DIA = .050-.082
- 2 TONGUE MATERIAL THK. = .018 ± .002
- 3 BODY FINISH = TIN PLATE (MIL-T-10727).000100 MIN THK

QTY.	DESCRIPTION	PART NO
100	ON TAPE, 5M BOX	2-323011-2
1000	ON TAPE, 1G BOX	2-323011-4
4000	ON TAPE, REEL	2-323011-2
—	LOOSE PIECE	323011

UNLESS OTHERWISE SPECIFIED DIMENSIONS ARE IN INCHES. TOLERANCES ON: DECIMALS ± .004 ANGLES ±		CONTRACT NO		AMP AMP INCORPORATED Harrisburg Pa	
MATERIAL INSULATION: NYLON - YELLOW BODY & SLEEVE: COPPER (ASTM B152)		DR UTA/RFB 10-2-85		NAME TERMINAL	
FINISH BODY: 3		APPD [Signature] 2-13-86		P.I.D.G., SLOTTED RING TONGUE	
		DSGN APPD		WIRE SIZE: 26-22	
		OTHER APPD		DRAWING NO 323011	
		SIZE B		FSCM NO 00779	
		SCALE NTS		SHEET 1 OF 1	

CUSTOMER DRAWING