

4

3

2

1

THIS DRAWING IS UNPUBLISHED. RELEASED FOR PUBLICATION  
 © COPYRIGHT - By - ALL RIGHTS RESERVED.

LOC	DIST	REVISIONS			
P	LTR	DESCRIPTION	DATE	DWN	APVD
G	14	U1	REVISED PER ECO-11-004587	11MAR11	RK HMR

WIRE RANGE	E13288 Listed	LR7189 Certified
22-16 AWG SOLID OR STRANDED	22-16 AWG SOLID OR STRANDED	22-16 AWG SOLID OR STRANDED

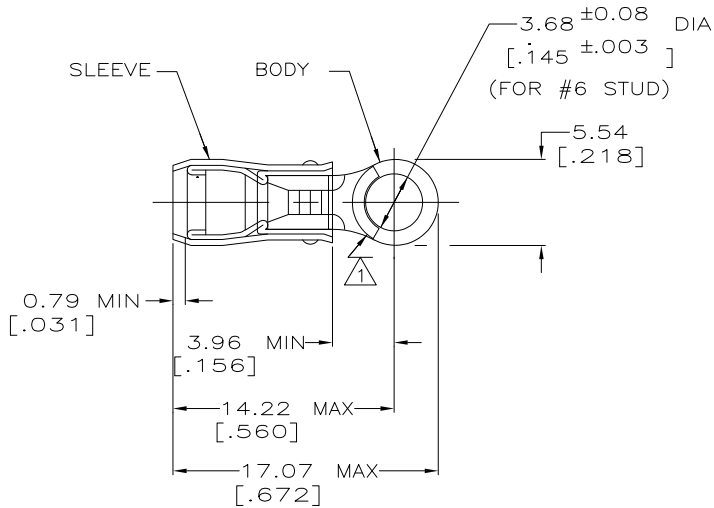

△ STAMP AMP 22-18\* APPROX AS SHOWN  
 22-16 TERMINALS ARE STAMPED 22-18 IN  
 ACCORDANCE WITH MILITARY SPEC MIL-T-7928  
 COMMERCIAL WIRE RANGE IS 22-16

- 2 WIRE INSULATION DIA: 2.03 - 3.18  
 [.080 - .125]
- 3 TONGUE MATERIAL THK: 0.79 ± 0.05  
 [.031 ± .002]

MILITARY P/N AND CLASS	QUANTITY	PACKAGE TYPE	PART NO
-	100	LOOSE PIECE, BOX	8-36149-1
MS25036-101 CLASS 2	5000	ON TAPE, REEL	2-36149-2
MS25036-101 CLASS 1 & 2	1000	LOOSE PIECE	36149

AMP INCORPORATED CUSTOMER SERVICE SYSTEMS		MAX RECOMMENDED OPERATING TEMPERATURE: 105° C MAX	DIMENSIONS: MM [ INCHES ]		TOLERANCES UNLESS OTHERWISE SPECIFIED:	TE Connectivity NAME: RE HERSEY PRODUCT SPEC: UL 486A APPLICATION SPEC: NOT AVAILABLE	
FOR ADDITIONAL PRODUCT INFORMATION OR COPIES OF DRAWINGS AND TECHNICAL DOCUMENTS	PRODUCT INFORMATION CENTER 1-800-522-6752	VOLTAGE RATING: 300 V MAX			0 PLC ± - 1 PLC ± - 2 PLC ± 0.20[.008] 3 PLC ± - 4 PLC ± - ANGLES ± -	APVD: ML ELLIS 9/8/93	RESTRICTED TO
FOR APPLICATION TOOLING INFORMATION	TOOLING ASSISTANCE CENTER 1-800-722-1111	CIRCULAR MIL AREA: 0.26-1.65mm² [509-3,260] CIR MILS SOLID OR STRANDED	MATERIAL: COPPER PER ASTM B-152 SLEEVE, RED NYLON	FINISH: TIN PLATE PER ASTM B545	WEIGHT: -	SIZE: A3 CAGE CODE: 00779 DRAWING NO: C=36149	SCALE: NTS SHEET: 1 OF 2 REV: U1
FOR ORDER ENTRY	1-800-526-5142				CUSTOMER DRAWING		

1470-19 (3/11)

4

3

2

1

THIS DRAWING IS UNPUBLISHED. RELEASED FOR PUBLICATION  
 © COPYRIGHT - By - ALL RIGHTS RESERVED.

LOC	DIST	REVISIONS			
P	LTR	DESCRIPTION	DATE	DWN	APVD
G	14	SEE SHEET 1	-	-	-

3 STRIPES EQUALLY SPACED FOR COLOR CODE: SEE TABLE

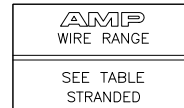
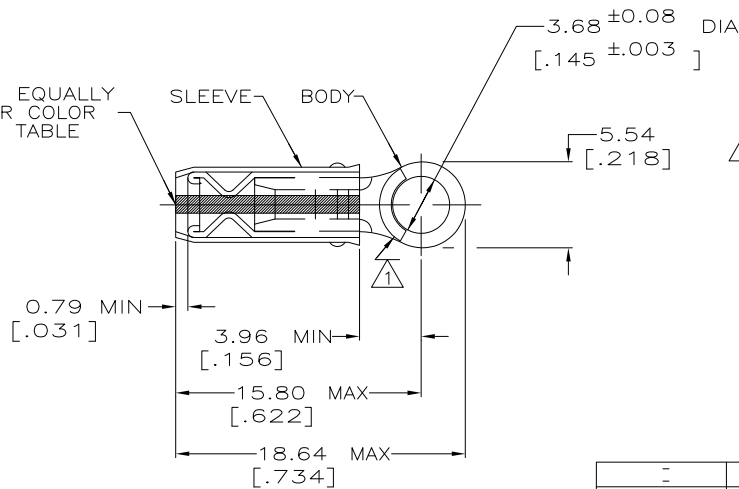

1 STAMP AMP APPROX AS SHOWN SEE TABLE BELOW

2 WIRE INSULATION DIA: 0.97 - 2.79 FOR 22 AWG [.038 - .110]  
 1.17 - 2.79 FOR 20 AWG [.046 - .110]  
 1.42 - 2.79 FOR 18 AWG [.056 - .110]

3 TONGUE MATERIAL THK: 0.79±0.05 [.031±.002]

MILITARY P/N AND CLASS	STRIPE COLOR	STAMPING	WIRE SIZE	QUANTITY	PACKAGE TYPE	PART NO
-	WHITE	18*	18	100	LOOSE PIECE, BOX	9-36149-1
-	RED	20*	20	100	LOOSE PIECE, BOX	7-36149-1
-	GREEN	22*	22	100	LOOSE PIECE, BOX	6-36149-1
M7928/1-30 CLASS 1 & 2	WHITE	18*	18	1000	LOOSE PIECE	2-36149-5
M7928/1-21 CLASS 1 & 2	RED	20*	20	1000	LOOSE PIECE	2-36149-4
M7928/1-12 CLASS 1 & 2	GREEN	22*	22	1000	LOOSE PIECE	2-36149-3

AMP INCORPORATED  
CUSTOMER SERVICE SYSTEMS

MAX RECOMMENDED OPERATING TEMPERATURE: 105° C MAX

VOLTAGE RATING: 300 V MAX

WIRE RANGE: 22 0.38mm<sup>2</sup> [754]  
 20 0.60mm<sup>2</sup> [1,186]  
 18 0.96mm<sup>2</sup> [1,900]  
 STRANDED

DIMENSIONS:

MM [INCHES]



TOLERANCES UNLESS OTHERWISE SPECIFIED:

0 PLC ± -  
 1 PLC ± -  
 2 PLC ± 0.20[.008]  
 3 PLC ± -  
 4 PLC ± -  
 ANGLES ± -

MATERIAL: COPPER PER ASTM B-152 SLEEVE, RED NYLON

FINISH: TIN PLATE PER ASTM B545

DWN DK SCHRUM 9/8/93

CHK RE HERSEY 9/8/93

APVD ML ELLIS 9/8/93

PRODUCT SPEC

APPLICATION SPEC

NOT AVAILABLE

WEIGHT -

CUSTOMER DRAWING

**TE** TE Connectivity

NAME: TERMINAL, RING TONGUE, I.R., PIDG™ WIRE SIZE, 22-16 AWG

SIZE: A3 CAGE CODE: 00779 DRAWING NO: C=36149

RESTRICTED TO: -

SCALE: NTS SHEET: 2 of 2 REV: U1