

4

3

2

1

THIS DRAWING IS UNPUBLISHED. RELEASED FOR PUBLICATION  
 © COPYRIGHT - By - ALL RIGHTS RESERVED.

LOC	DIST	REVISIONS			
P	LTR	DESCRIPTION	DATE	DWN	APVD
G	14				
	E2	REVISED PER ECO-11-004917	11MAR11	RK	HMR

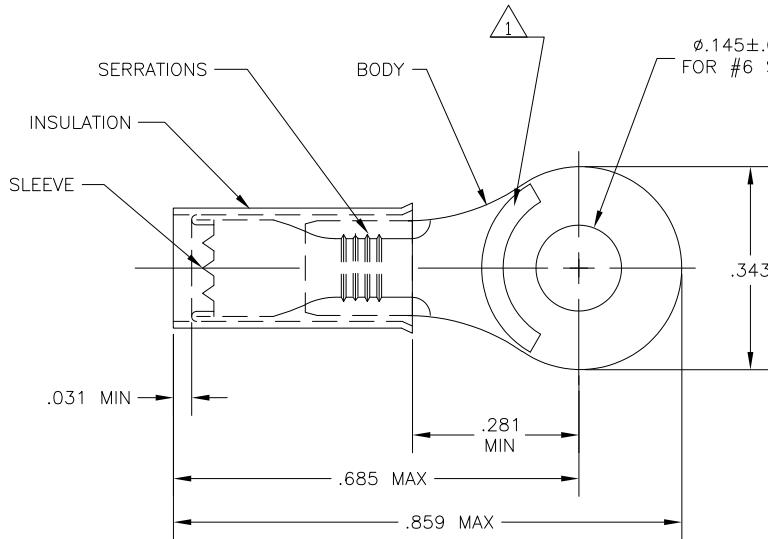

- 1 STAMP MAY BE ON TOP OR BOTTOM
- 2 FOR .115 TO .170 WIRE INSULATION DIA.
- 3 MATERIAL TONGUE THK IS .031±.002

100	LOOSE PIECE, BOX	INSULATION: NYLON, COLOR BLUE	8-36158-1
1	36158 ON TAPE	SLEEVE: COPPER PER ASTM B152 TIN PLATE PER ASTM B545	2-36158-1
1	WIRE TERMINAL	BODY: COPPER PER ASTM B152 TIN PLATE PER ASTM B545	36158
QTY	DESCRIPTION	MATERIAL	PART NO

THIS DRAWING IS A CONTROLLED DOCUMENT.

DIMENSIONS: INCHES	TOLERANCES UNLESS OTHERWISE SPECIFIED:	DWN jr_ruth 17MAR09	<b>STE</b> TE Connectivity	
0 PLC ± -	1 PLC ± -	CHK TOM MICHELUTTI 17MAR09		
	2 PLC ± -	APVD TOM MICHELUTTI 17MAR09	NAME TERMINAL, PIDG RING TONGUE, WIRE SIZE 16-14 AWG	
	3 PLC ± .008	PRODUCT SPEC	RESTRICTED TO	
MATERIAL SEE TABLE	FINISH SEE TABLE	APPLICATION SPEC	SIZE A3	CAGE CODE 00779
		WEIGHT	DRAWING NO C-36158	RESTRICTED TO
		CUSTOMER DRAWING	SCALE 8:1	SHEET 1 of 1
			REV E2	