

THIS DRAWING IS UNPUBLISHED. RELEASED FOR PUBLICATION
 © COPYRIGHT - By - ALL RIGHTS RESERVED.

| LOC | DIST | REVISIONS | | | | | |
|-----|------|-----------|-----|---------------------------|---------|-----|------|
| | | P | LTR | DESCRIPTION | DATE | DWN | APVD |
| G | 14 | | P2 | REVISED PER ECO-11-004820 | 11MAR11 | RK | HMR |

| | | |
|--------------------------------|--------------------------------|--------------------------------|
| AMP WIRE RANGE | Listed | LR7189 Certified |
| 12-10 AWG SOLID OR STRANDED | 12-10 AWG SOLID OR STRANDED | 12-10 AWG SOLID OR STRANDED |

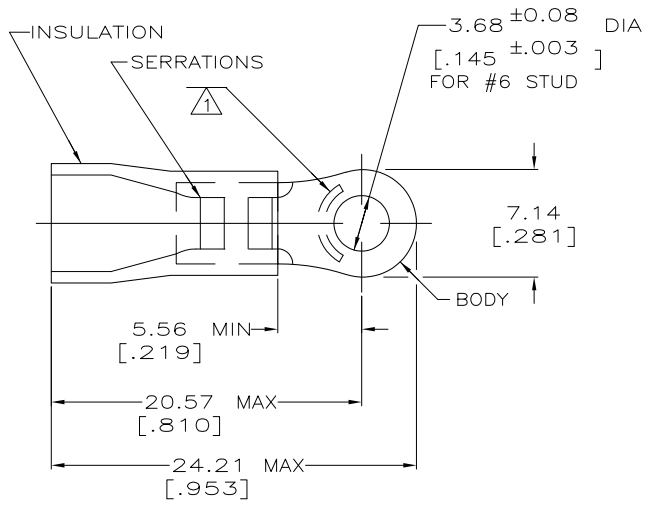

- 1 STAMP AMP 12-10* APPROX AS SHOWN
- 2 WIRE INSULATION DIA: .150-.250
- 3 TONGUE MATERIAL THK: 0.99^{±0.05} [0.039^{±0.002}]
- 4 MATERIAL: BODY - CU PER ASTM B152
SLEEVE - PVC, COLOR - YELLOW

| | | |
|------|---------------|-----------|
| 50 | LOOSE PC,BOX | 8-34852-2 |
| 2000 | ON TAPE, REEL | 2-34852-1 |
| - | LOOSE PIECE | 34852 |
| QTY | PACKAGE TYPE | PART NO. |

| | | | | | | |
|--|--|--|--|---|-----------------------------------|---|
| AMP INCORPORATED CUSTOMER SERVICE SYSTEMS | | MAX RECOMMENDED OPERATING TEMPERATURE: 105°C [221°F] | THIS DRAWING IS A CONTROLLED DOCUMENT. | | DWN DK SCHRUM 08/06/92 | TE Connectivity |
| FOR ADDITIONAL PRODUCT INFORMATION OR COPIES OF DRAWINGS AND TECHNICAL DOCUMENTS | PRODUCT INFORMATION CENTER 1-800-522-6752 | VOLTAGE RATING: N/A | DIMENSIONS: mm [INCHES] | TOLERANCES UNLESS OTHERWISE SPECIFIED: 0 PLC ±- 1 PLC ±- 2 PLC ± 0.20[.008] 3 PLC ±- 4 PLC ±- ANGLES ±- | CHK RE HERSEY 11/10/92 | |
| FOR APPLICATION | TOOLING ASSISTANCE CENTER 1-800-722-1111 | CIRCULAR MIL AREA: 2.62-6.64mm² [5,180-13,100] SOLID OR STRANDED | | | APD M BARNABA 11/10/92 | TERMINAL, RING TONGUE, PLASTI-GRIP WIRE SIZE 12-10 AWG |
| FOR ORDER ENTRY | 1-800-526-5142 | | MATERIAL - 4 | FINISH TIN PER ASTM B545 | PRODUCT SPEC 108-1034 | RESTRICTED TO |
| | | | | | APPLICATION SPEC NOT AVAILABLE | SIZE CAGE CODE DRAWING NO |
| | | | | | WEIGHT - | A3 00779 C=34852 |
| | | | | | CUSTOMER DRAWING | SCALE 4:1 SHEET 1 of 1 REV P2 |