

DRAWING MADE IN THIRD ANGLE PROJECTION
 THIS DRAWING IS UNPUBLISHED. RELEASED FOR PUBLICATION .19
 © COPYRIGHT 19 BY AMP INCORPORATED. ALL INTERNATIONAL RIGHTS RESERVED.

LOC	DIST	P	F	ZONE	LTR	REVISIONS	DATE	APPD
G	14				D	REVISED PER 0720-0513-95	27MAR95	NRB

METRIC
 DIMENSIONS LISTED IN mm [INCHES]

AMP WIRE RANGE	E13288 Listed
12-10 AWG STRANDED	12-10 AWG STRANDED
LR7189 Certified	MILITARY P/N AND CLASS
NOT CERTIFIED	NOT APPLICABLE

- ① STAMP AMP 12-10* APPROX AS SHOWN
- ② TIN PL 0.00254 [.000100] MIN THK
PER MIL-T-10727
- ③ GOLD PLATE 0.00127 [.000050] MIN EXT THK
PER MIL-G-45204 OVER NICKEL PLATE
0.00076 [.000030] MIN EXT THK
PER QQ-C-290

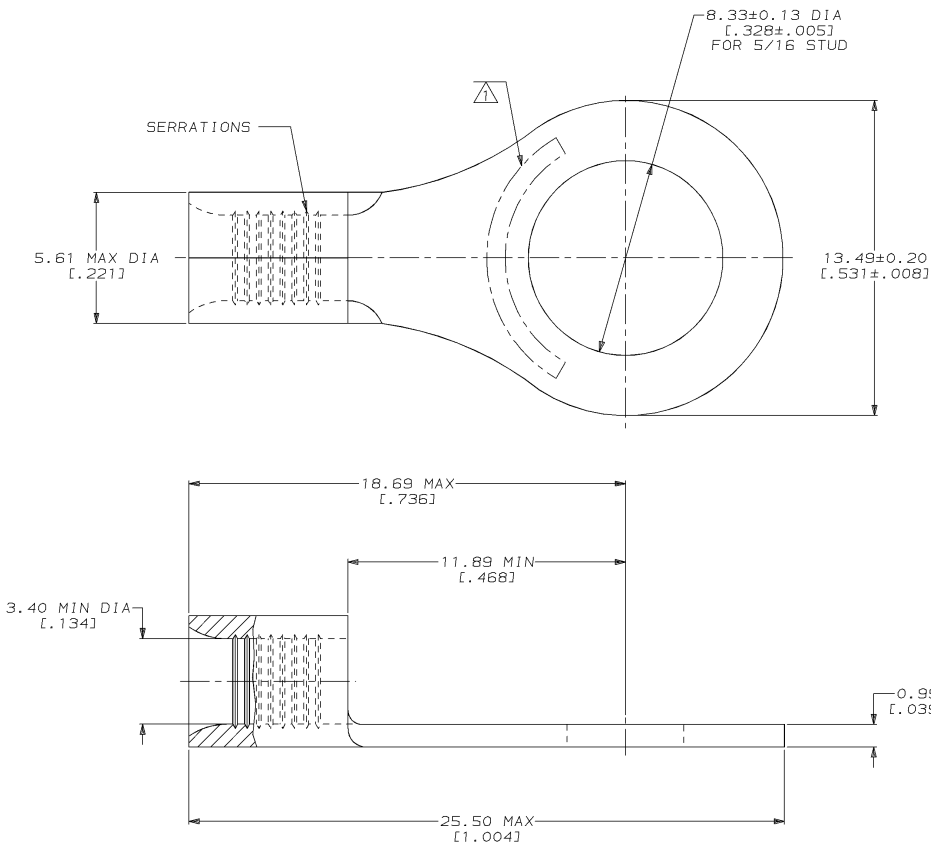

	2-31123-2
	31123
FINISH	PART NO

AMP INCORPORATED CUSTOMER SERVICE SYSTEMS		MAX RECOMMENDED OPERATING TEMPERATURE: 170°C MAX	DO NOT SCALE PRINT. UNLESS SPECIFIED DIMENSIONS IN mm [INCHES] TOLERANCES ON: 2 PLC DEC # - 3 PLC DEC # - ANGLES ± -	DR 2-9-93 TA BRINKMAN CHK 2-9-93 DA PATTERSON APPD 2-9-93 DE MILLER	AMP AMP Incorporated Harrisburg, PA 17105-3608
FOR ADDITIONAL PRODUCT INFORMATION OR COPIES OF DRAWINGS AND TECHNICAL DOCUMENTS	PRODUCT INFORMATION CENTER 1-800-522-6752	VOLTAGE RATING: NOT APPLICABLE	MATERIAL COPPER PER ASTM B-152 ANNEALED	NAME TERMINAL, RING TONGUE, BUDGET	
FOR APPLICATION TOOLING INFORMATION	TOOLING ASSISTANCE CENTER 1-800-722-1111	WIRE CROSS SECTIONAL AREA RANGE: 2.62-5.64mm² [5, 180-13, 100] CIR MILS STRANDED	FINISH SEE TABLE	APPLICATION SPEC -	SIZE C 00779
FOR ORDER ENTRY	1-800-526-5142	THIS DRAWING IS A CONTROLLED DOCUMENT FOR AMP INCORPORATED. IT IS SUBJECT TO CHANGE AND THE CONTROLLING ENGINEERING ORGANIZATION SHOULD BE CONTACTED FOR THE LATEST REVISION.		PRODUCT SPEC -	DRAWING NO C-31123
AMP 1471-6 REV 3-92				WEIGHT -	SCALE 8:1
					SHEET 1 OF 1

27-MAR-95 08:46:11 amp26463 /files/dept1123/dwg1123/u.bodies/u.12-10

CUSTOMER DRAWING