

THIS DRAWING IS UNPUBLISHED. RELEASED FOR PUBLICATION
 © COPYRIGHT - By - ALL RIGHTS RESERVED.

LOC	DIST	REVISIONS					
G	14	P	LTR	DESCRIPTION	DATE	DWN	APVD
		P1		REVISED PER ECO-11-004917	11MAR11	RK	HMR

AMP WIRE RANGE	Listed FILE E13288	LR7189 Certified
22-16 AWG SOLID OR STRANDED	22-16 AWG SOLID OR STRANDED	22-16 AWG SOLID OR STRANDED

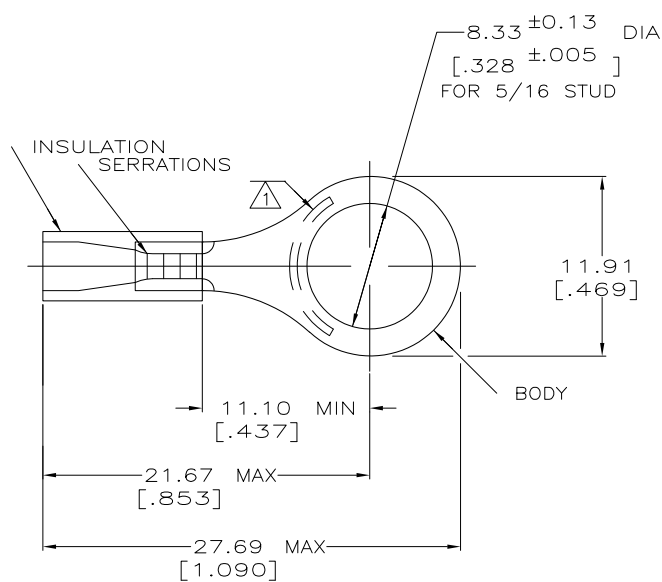

- 1 STAMP AMP 22-18* APPROX AS SHOWN
22-16 TERMINALS ARE STAMPED 22-18 IN
ACCORDANCE WITH MILITARY SPEC MIL-T-7928
COMMERCIAL WIRE RANGE IS 22-16
- 2 WIRE INSULATION DIA: 2.67-3.56 [0.105-.140]
- 3 TONGUE MATERIAL THK: 0.79±0.05 [0.031±0.002]
- 4 MATERIAL: BODY - CU PER ASTM B152
SLEEVE - PVC, COLOR - RED
- 5 MATERIAL: BODY - CU PER ASTM B152
SLEEVE - PVC, COLOR - BLACK

QTY	PACKAGE TYPE	PART NO
25	LOOSE PC,BAG	8-34151-5
100	LOOSE PC,BOX	8-34151-1
5000	ON TAPE, REEL	2-34151-3
5000	ON TAPE, REEL	2-34151-1
1000	LOOSE PIECE	34151

AMP INCORPORATED CUSTOMER SERVICE SYSTEMS		MAX RECOMMENDED OPERATING TEMPERATURE: 105°C [221°F]	THIS DRAWING IS A CONTROLLED DOCUMENT.		DWN DK SCHRUM 08/06/92	STE TE Connectivity	
FOR ADDITIONAL PRODUCT INFORMATION OR COPIES OF DRAWINGS AND TECHNICAL DOCUMENTS	PRODUCT INFORMATION CENTER 1-800-522-6752	VOLTAGE RATING: 600V MAX (1000V FIXTURE OR SIGN)	DIMENSIONS: mm[INCHES]	TOLERANCES UNLESS OTHERWISE SPECIFIED: 0 PLC ± - 1 PLC ± - 2 PLC ± 0.20[.008] 3 PLC ± - 4 PLC ± - ANGLES ± -	CHK RE HERSEY 11/10/92	NAME TERMINAL, RING TONGUE, PLASTI-GRIP WIRE SIZE, 22-16 AWG	
FOR APPLICATION	TOOLING ASSISTANCE CENTER 1-800-722-1111	CIRCULAR MIL AREA: 0.26-1.65mm² [509-3260] SOLID OR STRANDED		FINISH TIN PER ASTM B545	APD M BARNABA 11/10/92	PRODUCT SPEC UL 486A	RESTRICTED TO
FOR ORDER ENTRY	1-800-526-5142	THIS DRAWING IS A CONTROLLED DOCUMENT FOR AMP INCORPORATED. IT IS SUBJECT TO CHANGE AND THE CONTROLLING ENGINEERING ORGANIZATION SHOULD BE CONTACTED FOR THE LATEST REVISION.	MATERIAL SEE NOTES	WEIGHT	APPLICATION SPEC	SIZE A3	CAGE CODE 00779
CUSTOMER DRAWING						DRAWING NO C=34151	SCALE 4:1
						SHEET 1 of 1	REV P1