

THIS DRAWING IS UNPUBLISHED. RELEASED FOR PUBLICATION  
 © COPYRIGHT - By - ALL RIGHTS RESERVED.

LOC	DIST	REVISIONS					
G	14	P	LTR	DESCRIPTION	DATE	DWN	APVD
		N2		REVISED PER ECO-11-004820	11MAR11	RK	HMR

<b>AMP</b> WIRE RANGE	Listed FILE E13288	LR7189 Certified
12-10 AWG SOLID OR STRANDED	12-10 AWG SOLID OR STRANDED	12-10 AWG SOLID OR STRANDED

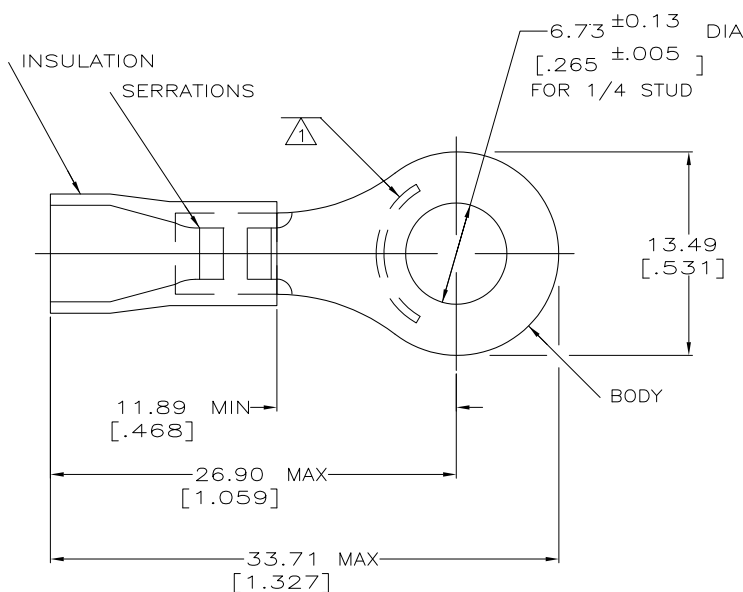

- 1 STAMP AMP 12-10\* APPROX AS SHOWN
- 2 WIRE INSULATION DIA: .150-.250
- 3 TONGUE MATERIAL THK: 0.99 ±0.05 [.039 ±.002]
- 4 TIN PLATE PER ASTM B 545
- 5 GOLD FLASH PLATE
- 6 INSULATION COLOR, YELLOW FOR P/N'S 34855, 2-34855-1, 8-34855-2 & 8-34855-4
- 7 INSULATION COLOR, RED FOR P/N'S 34855-1 & 2-34855-7
- 8 MATERIAL: BODY - CU PER ASTM B152  
SLEEVE - PVC, COLOR - SEE NOTES 6 & 7

4	LOOSE PC,BLS	8-34855-4
50	LOOSE PC,BOX	8-34855-2
2500	ON TAPE, REEL	2-34855-7
2500	ON TAPE, REEL	2-34855-1
-	LOOSE PIECE	34855-1
-	LOOSE PIECE	34855
QTY	PACKAGE TYPE	PART NO.

**AMP INCORPORATED**  
**CUSTOMER SERVICE SYSTEMS**

FOR ADDITIONAL PRODUCT INFORMATION OR COPIES OF DRAWINGS AND TECHNICAL DOCUMENTS  
 PRODUCT INFORMATION CENTER  
 1-800-522-6752

FOR APPLICATION TOOLING INFORMATION  
 TOOLING ASSISTANCE CENTER  
 1-800-722-1111

FOR ORDER ENTRY  
 1-800-526-5142

MAX RECOMMENDED OPERATING TEMPERATURE:  
 105°C [221°F]

VOLTAGE RATING:  
 N/A

CIRCULAR MIL AREA:  
 2.62-6.64mm² [5,180-13,100]  
 SOLID OR STRANDED

THIS DRAWING IS A CONTROLLED DOCUMENT.

DIMENSIONS:  
 mm [INCHES]

TOLERANCES UNLESS OTHERWISE SPECIFIED:  
 0 PLC ±-  
 1 PLC ±-  
 2 PLC ±-  
 3 PLC ± 0.20[.008]  
 4 PLC ±-  
 ANGLES ±-

MATERIAL:

FINISH: SEE NOTES 4 & 5

DWN: DK SCHRUM 08/06/92  
 CHK: RE HERSEY 11/10/92  
 APVD: M BARNABA 11/10/92

NAME: **STE** TE Connectivity

PRODUCT SPEC: 108-1034  
 APPLICATION SPEC: NOT AVAILABLE

TERMINAL, RING TONGUE, PLASTI-GRIP  
 WIRE SIZE: 12-10 AWG

SIZE: A3 CAGE CODE: 00779 DRAWING NO: C=34855 RESTRICTED TO: -

WEIGHT: -

CUSTOMER DRAWING SCALE: 4:1 SHEET: 1 of 1 REV: N2