

4

3

2

1

THIS DRAWING IS UNPUBLISHED. RELEASED FOR PUBLICATION
 © COPYRIGHT - By - ALL RIGHTS RESERVED.

LOC	DIST	REVISIONS			
P	LTR	DESCRIPTION	DATE	DWN	APVD
	T2	REVISED PER ECO-11-004587	11MAR11	RK	HMR

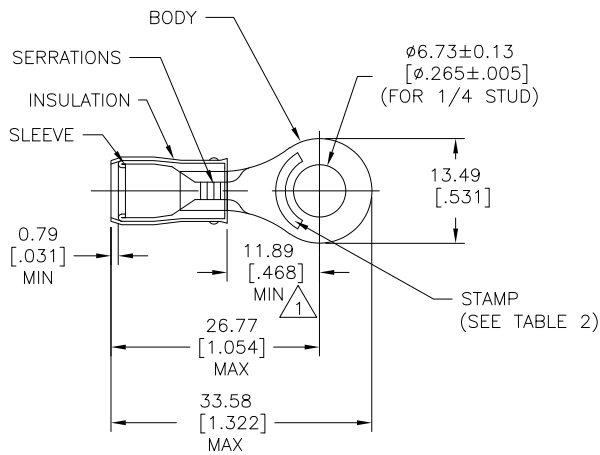

STYLE "A" - STANDARD

- 1 DIMENSION APPLIES FROM EDGE OF METAL WIRE BARREL TO CENTER OF STUD.
- 2 TONGUE MATERIAL THK 1.02±.05 [.040±.002]
- 3 105°C MAX OPERATING TEMPERATURE
- 4 300 VOLT MAX.
- 5 CIRCULAR MIN AREA: 2.62-6.64 mm² [5180-13100] SOLID OR STRANDED
- 6 UL LISTED E13288 12-10 AWG SOLID OR STRANDED
- 7 CSA CERTIFIED LR7189 12-10 AWG SOLID OR STRANDED
- 8 MILITARY MS25036-157 CLASS 1
- 9 MILITARY MS25036-157 CLASS 2

TABLE 1			
50	BODY & SLEEVE: COPPER PER ASTM B-152 TIN PLATE PER ASTM B-545	LOOSE PC, BOX	8-320569-2
500	INSULATION: NYLON PER ASTM D-4066, TYPE 1, COLOR: YELLOW	LOOSE PIECE	320569
QTY	MATERIAL & FINISH	PACKAGING	PART NO.

THIS DRAWING IS A CONTROLLED DOCUMENT.

DIMENSIONS:	TOLERANCES UNLESS OTHERWISE SPECIFIED:
mm [INCHES]	
0 PLC	± -
1 PLC	± 0.2 [.008]
2 PLC	± -
3 PLC	± -
4 PLC	± -
ANGLES	± 0'30"
FINISH	-

DWN	ORSEP2008				
CHK	ORSEP2008				
APVD	ORSEP2008				
NAME					
PRODUCT SPEC		TERMINAL RING TONGUE, NYLON, PIDG, WIRE SIZE: 12-10			
APPLICATION SPEC		SIZE	CAGE CODE	DRAWING NO	RESTRICTED TO
WEIGHT	-	A3	00779	C-320569	-
CUSTOMER DRAWING		SCALE	2:1	SHEET	1 of 2
				REV	T2

TABLE 2

PART NO.	COLOR STRIPE	WIRE SIZE	FOR WIRE INSULATION OD	AMP	STYLE	PART NO. ON TAPE
8-320569-2	NONE	12-10	3.81-5.84 [.150-.230]	AMP 12-10*	"A"	-
320569	NONE	12-10	3.81-5.84 [.150-.230]	AMP 12-10*	"A"	2-320569-3

MATERIAL SEE TABLE 1

4

3

2

1

THIS DRAWING IS UNPUBLISHED. RELEASED FOR PUBLICATION
 © COPYRIGHT - By - ALL RIGHTS RESERVED.

LOC	DIST	REVISIONS				
P	LTR	DESCRIPTION	DATE	OWN	APVD	
G	02	SEE SHEET 1	-	-	-	

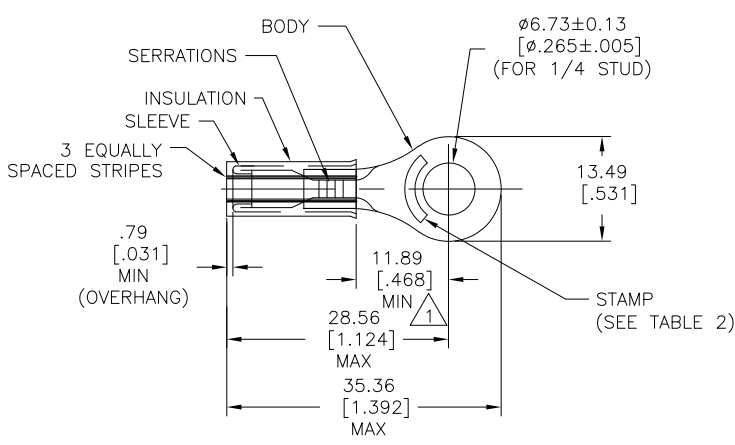

STYLE "B" - INSULATION RESTRICTING

- 1 DIMENSION APPLIES FROM EDGE OF METAL WIRE BARREL TO CENTER OF STUD.
- 2 TONGUE MATERIAL THK 1.02±.05 [.040±.002]
- 3 105°C MAX OPERATING TEMPERATURE
- 4 300 VOLT MAX.
- 5 CIRCULAR MIN AREA: 2.62-6.64 mm² [5180-13100] SOLID OR STRANDED
- 6 MILITARY M7928/1-59 CLASS 1
- 7 MILITARY M7928/1-66 CLASS 1
- 8 MILITARY M7928/1-59 CLASS 2
- 9 MILITARY M7928/1-66 CLASS 2

TABLE 1			
QTY	MATERIAL & FINISH	PACKAGING	PART NO.
500	BODY: COPPER PER ASTM B-152 TIN PLATE PER ASTM B-545 SLEEVE: COPPER PER ASTM B-152 NICKEL PLATE PER QQ-N-290 INSULATION: NYLON PER ASTM D-4066, TYPE 1 COLOR: YELLOW	LOOSE PIECE	2-320569-6
			2-320569-5

TABLE 2						
PART NO.	COLOR STRIPE	WIRE SIZE	FOR WIRE INSULATION OD	AMP	STYLE	PART NO. ON TAPE
2-320569-6	BROWN	10	3.02-5.08 [.119-.200]	AMP 10*	"B"	2-320569-8
2-320569-5	YELLOW	12	2.41-5.08 [.095-.200]	AMP 12*	"B"	2-320569-7
						OBsolete

THIS DRAWING IS A CONTROLLED DOCUMENT.

DIMENSIONS: mm [NCHES]	TOLERANCES UNLESS OTHERWISE SPECIFIED:
0 PLC	± -
1 PLC	± 0.2 [.008]
2 PLC	± -
3 PLC	± -
4 PLC	± -
ANGLES	± 0.30'
FINISH	-

MATERIAL: SEE TABLE 1

OWN RAGHAVENDRA 08SEP2008	 TE Connectivity	NAME	RESTRICTED TO
CHK T MICHIELUTTI 08SEP2008		TERMINAL RING TONGUE, NYLON, PIDG, WIRE SIZE: 12-10	
APVD T MICHIELUTTI 08SEP2008		SIZE CAGE CODE DRAWING NO	
PRODUCT SPEC		A300779 C=320569	
APPLICATION SPEC	WEIGHT	SCALE 2:1	SHEET 2 of 2
WEIGHT	CUSTOMER DRAWING	REV T2	