

4

3

2

1

THIS DRAWING IS UNPUBLISHED. RELEASED FOR PUBLICATION
 © COPYRIGHT - By - ALL RIGHTS RESERVED.

LOC	DIST	REVISIONS			
P	LTR	DESCRIPTION	DATE	DWN	APVD
G	14	R1	REVISED PER ECO-11-004587	11MAR11	RK HMR

AMP WIRE RANGE	Listed	LR7189 Certified
16-14 AWG SOLID OR STRANDED	16-14 AWG SOLID OR STRANDED	16-14 AWG SOLID OR STRANDED

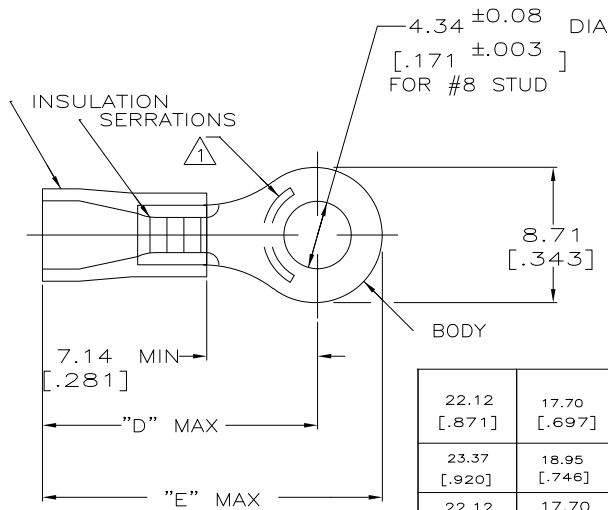

- △1 STAMP AMP 16-14* APPROX AS SHOWN
- 2 TONGUE MATERIAL THK: $0.79^{+0.05}$ [0.031 ±0.002]
- △3 SUPERSEDED BY 8-34160-1
- △4 MATERIAL: BODY - CU PER ASTM B152
SLEEVE - PVC, COLOR - BLUE

22.12 [.871]	17.70 [.697]	3.00-4.90 [.118-.193]	50	LOOSE PC, BAG	△3 8-34160-5
			5	LOOSE PC, BLS	8-34160-4
			100	LOOSE PC, BOX	8-34160-1
23.37 [.920]	18.95 [.746]	3.81-.635 [.150-.250]	5000	ON TAPE, REEL	2-34160-3
			-	LOOSE PIECE	2-34160-2
22.12 [.871]	17.70 [.697]	3.00-4.90 [.118-.193]	5000	ON TAPE, REEL	2-34160-1
			-	LOOSE PIECE	34160
"E"	"D"	WIRE INSULATION DIA	QTY	PACKAGE TYPE	PART NUMBER

AMP INCORPORATED CUSTOMER SERVICE SYSTEMS		MAX RECOMMENDED OPERATING TEMPERATURE: 105°C [221° F]	THIS DRAWING IS A CONTROLLED DOCUMENT.		DWN DK SCHRUM 02/08/93	TE Connectivity
FOR ADDITIONAL PRODUCT INFORMATION OR COPIES OF DRAWINGS AND TECHNICAL DOCUMENTS	PRODUCT INFORMATION CENTER 1-800-522-6752	VOLTAGE RATING: N/A	DIMENSIONS: MM [INCHES]	TOLERANCES UNLESS OTHERWISE SPECIFIED:	CHK RE HERSEY 8/15/93	
FOR APPLICATION	TOOLING ASSISTANCE CENTER	CIRCULAR MIL AREA: 1.04-2.62mm² [2,050-5,180] SOLID OR STRANDED		0 PLC ± - 1 PLC ± - 2 PLC ± 0.20[.008] 3 PLC ± - 4 PLC ± - ANGLES ± -	APVD M BARNABA 8/15/93	TERMINAL, RING TONGUE, PLASTI-GRIP, WIRE SIZE, 16-14 AWG
TOOLING INFORMATION	1-800-722-1111		MATERIAL	FINISH TIN PER ASTM B545	PRODUCT SPEC UL 486A	RESTRICTED TO
FOR ORDER ENTRY	1-800-526-5142	THIS DRAWING IS A CONTROLLED DOCUMENT FOR AMP INCORPORATED. IT IS SUBJECT TO CHANGE AND THE CONTROLLING ENGINEERING ORGANIZATION SHOULD BE CONTACTED FOR THE LATEST REVISION.			APPLICATION SPEC NOT AVAILABLE	SIZE A3
					WEIGHT -	CAGE CODE 00779
						DRAWING NO 34160
					CUSTOMER DRAWING	
					SCALE 4:1	SHEET 1 OF 1
						REV R1

1470-19 (3/11)