

THIS DRAWING IS UNPUBLISHED. RELEASED FOR PUBLICATION 19  
 © COPYRIGHT 19 BY AMP INCORPORATED. ALL INTERNATIONAL RIGHTS RESERVED.

LOC	DIST	P	F	ZONE	LTR	REVISIONS	DATE	APPD
G	14				C	REV / 0610-0026-99	12FEB99	JS SU

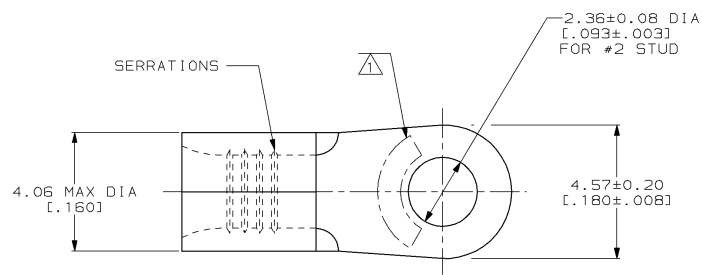

<b>AMP</b> WIRE RANGE	E13288 Listed
16-14 AWG STRANDED	16-14 AWG STRANDED
LR7189 Certified	MILITARY P/N AND CLASS
NOT CERTIFIED	NOT APPLICABLE

△ STAMP AMP 16-14\* APPROX AS SHOWN

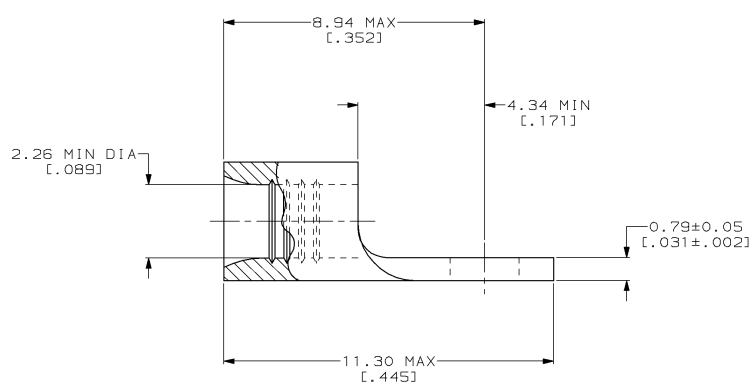

**AMP INCORPORATED  
CUSTOMER SERVICE SYSTEMS**

FOR ADDITIONAL PRODUCT INFORMATION OR COPIES OF DRAWINGS AND TECHNICAL DOCUMENTS	PRODUCT INFORMATION CENTER 1-800-522-6752
FOR APPLICATION TOOLING INFORMATION	TOOLING ASSISTANCE CENTER 1-800-722-1111
FOR ORDER ENTRY	1-800-526-5142

MAX RECOMMENDED OPERATING TEMPERATURE: 170°C MAX
VOLTAGE RATING: NOT APPLICABLE
WIRE CROSS SECTIONAL AREA RANGE: 1.04-2.62mm <sup>2</sup> [2,050-5,180] CIR MILS STRANDED
THIS DRAWING IS A CONTROLLED DOCUMENT FOR AMP INCORPORATED. IT IS SUBJECT TO CHANGE AND THE CONTROLLING ENGINEERING ORGANIZATION SHOULD BE CONTACTED FOR THE LATEST REVISION.

DO NOT SCALE PRINT. UNLESS SPECIFIED DIMENSIONS IN mm [INCHES] TOLERANCES ON 2 PLC DEC # - 3 PLC DEC # - ANGLES ± -
MATERIAL COPPER PER ASTM B-152 ANNEALED
FINISH TIN PLATE 0.00254[0.000100] MIN THK PER ASTM B-545

DR 2-4-93 TA BRINKMAN
CHK 2-4-93 DA PATTERSON
APPD 2-4-93 DE MILLER
APPD 2-4-93 JL MECKLEY
PRODUCT SPEC -
APPLICATION SPEC -
WEIGHT -

326854 PART NO		
<b>AMP</b> AMP Incorporated Harrisburg, PA 17105-3608		
NAME <b>TERMINAL, RING TONGUE, BUDGET</b>		
SIZE C	CAGE CODE 00779	DRAWING NO C-326854
SCALE 10:1	SHEET 1 OF 1	