

THIS DRAWING IS UNPUBLISHED. RELEASED FOR PUBLICATION  
 © COPYRIGHT - By - ALL RIGHTS RESERVED.

LOC	DIST	REVISIONS			
P	LTR	DESCRIPTION	DATE	DWN	APVD
	K1	REVISED PER ECO-11-004917	11MAR11	RK	HMR

<b>AMP</b> WIRE RANGE	Listed FILE E13288	LR7189 Certified
22-16 AWG SOLID OR STRANDED	22-16 AWG SOLID OR STRANDED	22-16 AWG SOLID OR STRANDED

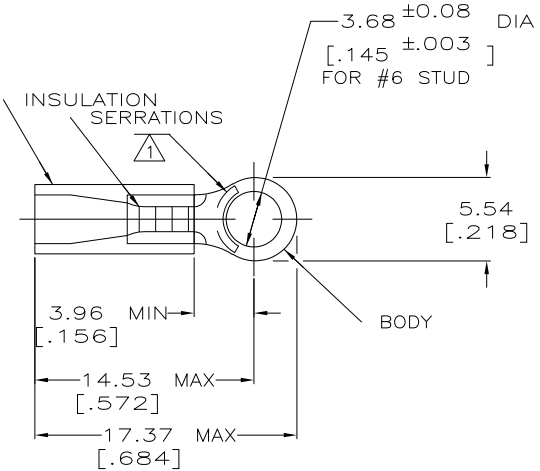

- 1 STAMP AMP 22-18\* APPROX AS SHOWN  
22-16 TERMINALS ARE STAMPED 22-18 IN  
ACCORDANCE WITH MILITARY SPEC MIL-T-7928  
COMMERCIAL WIRE RANGE IS 22-16
- 2 WIRE INSULATION DIA: 2.03-3.05 [0.080-.125]
- 3 TONGUE MATERIAL THK: 0.79 ±0.05 [0.031 ±0.002]
- 4 MATERIAL: BODY - CU PER ASTM B152  
SLEEVE - PVC, COLOR - RED

100	LOOSE PC,BOX	8-32945-1
5000	ON TAPE, REEL	2-32945-1
1000	LOOSE PIECE	32945
QTY	PACKAGE TYPE	PART NO.

AMP INCORPORATED CUSTOMER SERVICE SYSTEMS		MAX RECOMMENDED OPERATING TEMPERATURE: 105°C [221°F]	THIS DRAWING IS A CONTROLLED DOCUMENT.		DWN DK SCHRUM 08/06/92	TE Connectivity				
FOR ADDITIONAL PRODUCT INFORMATION OR COPIES OF DRAWINGS AND TECHNICAL DOCUMENTS	PRODUCT INFORMATION CENTER 1-800-522-6752	VOLTAGE RATING: 600V MAX (1000V FIXTURE OR SIGN)	DIMENSIONS: mm[INCHES]	TOLERANCES UNLESS OTHERWISE SPECIFIED: 0 PLC ±- 1 PLC ±- 2 PLC ±- 3 PLC ± 0.20[.008] 4 PLC ±- ANGLES ±-	CHK RE HERSEY 11/10/92	NAME				
FOR APPLICATION	TOOLING ASSISTANCE CENTER 1-800-722-1111	CIRCULAR MIL AREA: 0.26-1.65mm² [509-3260] SOLID OR STRANDED		0 PLC ±- 1 PLC ±- 2 PLC ± 0.20[.008] 3 PLC ±- 4 PLC ±- ANGLES ±-	APVD M BARNABA 11/10/92	PRODUCT SPEC UL 486A				
FOR ORDER ENTRY	1-800-526-5142	THIS DRAWING IS A CONTROLLED DOCUMENT FOR AMP INCORPORATED. IT IS SUBJECT TO CHANGE AND THE CONTROLLING ENGINEERING ORGANIZATION SHOULD BE CONTACTED FOR THE LATEST REVISION.	MATERIAL 4	FINISH TIN PER ASTM B545	APPLICATION SPEC -	SIZE A3	CAGE CODE 00779	DRAWING NO C=32945	RESTRICTED TO -	
					WEIGHT -	CUSTOMER DRAWING		SCALE 4:1	SHEET 1 of 1	REV K1