

THE DRAWING IS UNPUBLISHED. RELEASED FOR PUBLICATION. COPYRIGHT - By - ALL RIGHTS RESERVED.

LOC	REV	DESCRIPTION	DATE	OWN	APP
G	14				
P	LR				
C1		REVISED PER ECO-11-005027	11MAR11	RK	HMR

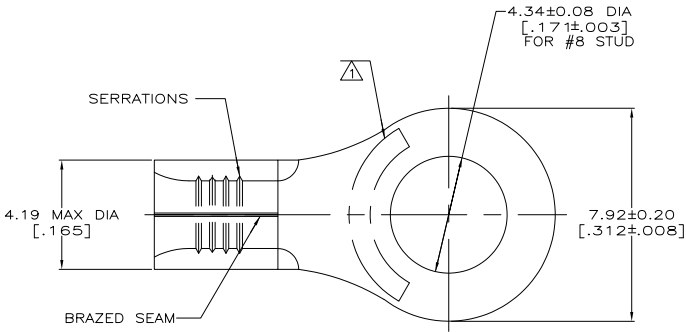

AMP WIRE RANGE	E13288 Listed
16-14 AWG SOLID OR STRANDED	16-14 AWG SOLID OR STRANDED
LR7189 Certified	MILITARY P/N AND CLASS
16-14 AWG SOLID OR STRANDED	NOT APPLICABLE

△ STAMP AMP 16-14* APPROX AS SHOWN

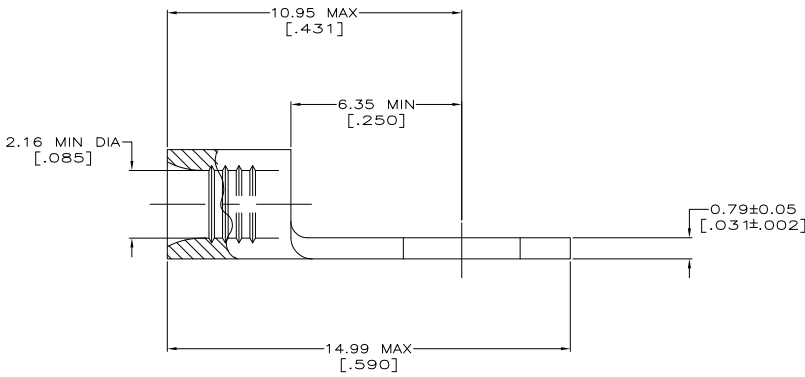

AMP INCORPORATED CUSTOMER SERVICE SYSTEMS		MAX RECOMMENDED OPERATING TEMPERATURE: 170° C MAX
FOR ADDITIONAL PRODUCT INFORMATION OR COPIES OF DRAWINGS AND TECHNICAL DOCUMENTS	PRODUCT INFORMATION CENTER 1-800-522-6752	VOLTAGE RATING: NOT APPLICABLE
FOR APPLICATION TOOLING INFORMATION	TOOLING ASSISTANCE CENTER 1-800-722-1111	WIRE CROSS SECTIONAL AREA RANGE: 1.04-2.62mm ² [2,050-5,180] CIR MILS SOLID OR STRANDED
FOR ORDER ENTRY	1-800-526-5142	THIS DRAWING IS A CONTROLLED DOCUMENT FOR AMP INCORPORATED. IT IS SUBJECT TO CHANGE AND THE CONTROLLING ENGINEERING ORGANIZATION SHOULD BE CONTACTED FOR THE LATEST REVISION.

50	LOOSE PIECE, BAG	8-324955-5
100	LOOSE PIECE, BOX	8-324955-1
5000	ON TAPE	2-324955-1
----	LOOSE PIECE	324955
QUANTITY	PACKAGE TYPE	PART NO

THIS DRAWING IS A CONTROLLED DOCUMENT.		BY TA BRINKMAN 3-17-93	TE Connectivity
DRAWN DA PATTERSON 3-17-93		CHK DE MILLER 3-17-93	
DIMENSIONS: MM(INCHES)	TO DIMENSIONS UNLESS OTHERWISE SPECIFIED:	PRODUCT SPEC	TERMINAL, RING TONGUE, SOLISTRAND™
	0 P/C # - 1 P/C # - 2 P/C # - 3 P/C # - 4 P/C # - ANGLES # -	APPLICATION SPEC	SIZE A2
MATERIAL COPPER PER ASTM B-152 ANNEALED	FINISH EN PLATE 0.00254(0.0010) MIN THK PER ASTM B-565	WEIGHT	DRAWING NO 00779
CUSTOMER DRAWING		SCALE	10:1
		SHEET	1 of 1
		REV	C1

1471-9 (5/11)

324955

A