

THIS DRAWING IS UNPUBLISHED. RELEASED FOR PUBLICATION
 © COPYRIGHT - By - ALL RIGHTS RESERVED.

LOC	DIST	REVISIONS			
P	LTR	DESCRIPTION	DATE	DWN	APVD
G	14				
		Z2	REVISED PER ECO-11-004587	11MAR11	RK HMR

AMP WIRE RANGE	Listed FILE E13288	LR7189 Certified
22-16 AWG SOLID OR STRANDED	22-16 AWG SOLID OR STRANDED	22-16 AWG SOLID OR STRANDED

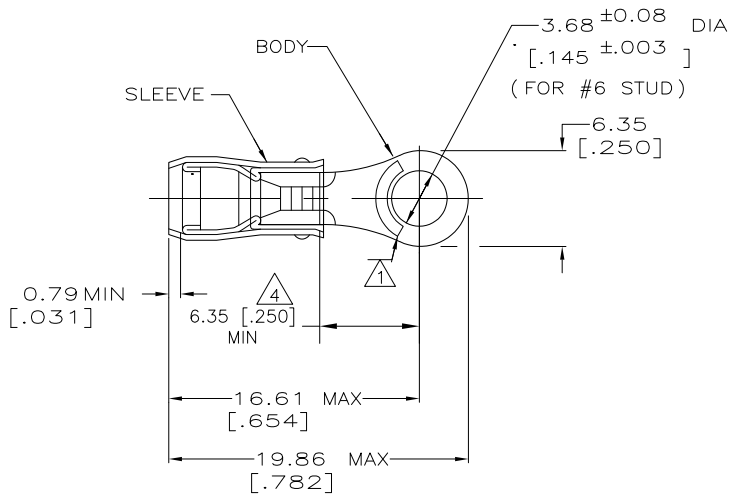

- ① STAMP AMP 22-18* APPROX AS SHOWN
22-16 TERMINALS ARE STAMPED 22-18 IN
ACCORDANCE WITH MILITARY SPEC MIL-T-7928
COMMERCIAL WIRE RANGE IS 22-16
- 2 WIRE INSULATION DIA: 2.03 - 3.18
[.080 - .125]
- 3 TONGUE MATERIAL THK: 0.79±0.05
[.031±.002]
- ④ DIMENSION APPLIES FROM EDGE OF METAL
WIRE BARREL TO CENTER OF STUD HOLE.
- ⑤ BODY - COPPER PER ASTM B-152
SLEEVE - NYLON
- ⑥ BODY - TIN PLATE PER ASTM B545
SLEEVE - COLOR - RED

--	100	LOOSE PIECE, BOX	7-51863-1
MS25036-102 CLASS 2	5000	ON TAPE, REEL	51863-1
MS25036-102 CLASS 1 & 2	1000	LOOSE PIECE	51863
MILITARY P/N AND CLASS	QTY	PACKAGE TYPE	PART NUMBER

AMP INCORPORATED CUSTOMER SERVICE SYSTEMS		MAX RECOMMENDED OPERATING TEMPERATURE: 105°C MAX	THIS DRAWING IS A CONTROLLED DOCUMENT.		DWN DK SCHRUM 9/8/93	TE Connectivity
FOR ADDITIONAL PRODUCT INFORMATION OR COPIES OF DRAWINGS AND TECHNICAL DOCUMENTS	PRODUCT INFORMATION CENTER 1-800-522-6752	VOLTAGE RATING: 300V MAX	DIMENSIONS: mm [INCHES]	TOLERANCES UNLESS OTHERWISE SPECIFIED:	9/8/93 M HERSEY	
FOR APPLICATION TOOLING INFORMATION	TOOLING ASSISTANCE CENTER 1-800-722-1111	CIRCULAR MIL AREA: 0.26-1.65mm² [509-3260] CIR MILS SOLID OR STRANDED		0 PLC ± - 1 PLC ± - 2 PLC ± - 3 PLC ± 0.20[.008] 4 PLC ± - ANGLES ± -	APVD M BARNABA 9/8/93	NAME TERMINAL, RING TONGUE, PIDG WIRE SIZE: 22-16 AWG
FOR ORDER ENTRY	1-800-526-5142	THIS DRAWING IS A CONTROLLED DOCUMENT FOR AMP INCORPORATED. IT IS SUBJECT TO CHANGE AND THE CONTROLLING ENGINEERING ORGANIZATION SHOULD BE CONTACTED FOR THE LATEST REVISION.	MATERIAL	FINISH	PRODUCT SPEC UL 486A	SIZE CAGE CODE DRAWING NO A3 00779 C=51863
			⑤	⑥	APPLICATION SPEC NOT AVAILABLE	RESTRICTED TO -
					WEIGHT -	CUSTOMER DRAWING
					SCALE NTS	SHEET 1 of 2 REV 22

THIS DRAWING IS UNPUBLISHED. RELEASED FOR PUBLICATION
 © COPYRIGHT - By - ALL RIGHTS RESERVED.

LOC	DIST	REVISIONS				
G	14	P	LTR	DATE	DWN	APVD
		22	REVISED PER ECO-11-004587	11MAR11	RK	HMR

AMP
WIRE RANGE

SEE TABLE
STRANDED

- 1 STAMP AMP APPROX AS SHOWN
SEE TABLE BELOW
- 2 WIRE INSULATION DIA:
 0.97 - 2.79 FOR 22 AWG
 [.038 - .110]
 1.17 - 2.79 FOR 20 AWG
 [.046 - .110]
 1.42 - 2.79 FOR 18 AWG
 [.056 - .110]
- 3 TONGUE MATERIAL THK: 0.79±0.05
 [.031±.002]
- 4 DIMENSION APPLIES FROM EDGE OF METAL
WIRE BARREL TO CENTER OF STUD HOLE.
- 5 BODY - COPPER PER ASTM B-152
SLEEVE - NYLON
- 6 BODY - TIN PLATE PER ASTM B545
SLEEVE - COLOR - RED

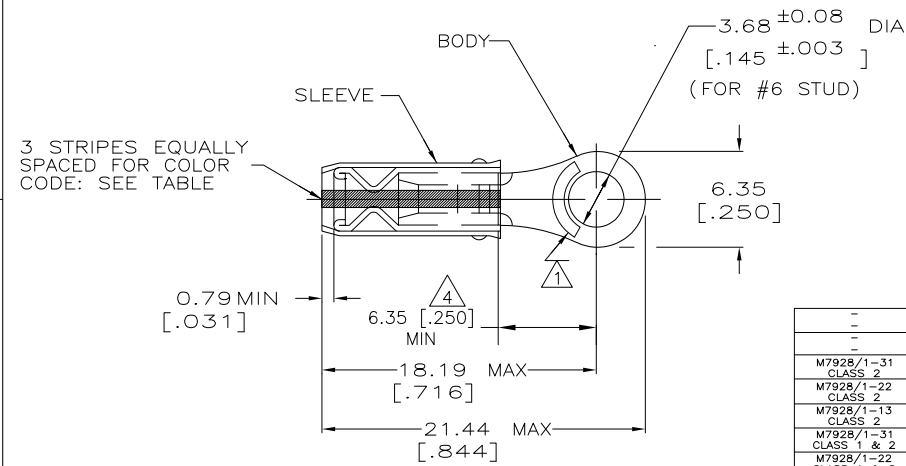

MILITARY P/N AND CLASS	STRIPE COLOR	STAMPING	WIRE SIZE	QTY	PACKAGE TYPE	PART NO.
-	WHITE	18*	18	100	LOOSE PIECE, BOX	9-51863-1
-	GREEN	22*	22	100	LOOSE PIECE, BOX	8-51863-1
M7928/1-31 CLASS 2	WHITE	18*	18	5000	ON TAPE, REEL	51863-7
M7928/1-22 CLASS 2	RED	20*	20	5000	ON TAPE, REEL	51863-6
M7928/1-13 CLASS 2	GREEN	22*	22	5000	ON TAPE, REEL	51863-5
M7928/1-31 CLASS 1 & 2	WHITE	18*	18	1000	LOOSE PIECE	51863-4
M7928/1-22 CLASS 1 & 2	RED	20*	20	1000	LOOSE PIECE	51863-3
M7928/1-13 CLASS 1 & 2	GREEN	22*	22	1000	LOOSE PIECE	51863-2

AMP INCORPORATED CUSTOMER SERVICE SYSTEMS		MAX RECOMMENDED OPERATING TEMPERATURE: 105°C	THIS DRAWING IS A CONTROLLED DOCUMENT.		DWN DK SCHRUM 9/8/93	TE Connectivity	
FOR ADDITIONAL PRODUCT INFORMATION OR COPIES OF DRAWINGS AND TECHNICAL DOCUMENTS	PRODUCT INFORMATION CENTER 1-800-522-6752	VOLTAGE RATING: 300V MAX	DIMENSIONS: mm [INCHES]	TOLERANCES UNLESS OTHERWISE SPECIFIED: 0 PLC ± - 1 PLC ± - 2 PLC ± - 3 PLC ± 0.20[.008] 4 PLC ± - ANGLES ± -	CHK RE HERSEY 9/8/93	NAME TERMINAL, RING TONGUE, I.R., PIDG, WIRE SIZE 22-16 AWG	
FOR APPLICATION	TOOLING ASSISTANCE CENTER 1-800-722-1111	WIRE RANGE CIR MIL AREA: 22 0.38mm² [75.4] 20 0.60mm² [1,186] 18 0.96mm² [1,900] STRANDED		MATERIAL	APVD M BARNABA 9/8/93	PRODUCT SPEC	RESTRICTED TO
FOR ORDER ENTRY	1-800-526-5142	THIS DRAWING IS A CONTROLLED DOCUMENT FOR AMP INCORPORATED. IT IS SUBJECT TO CHANGE AND THE CONTROLLING ENGINEERING ORGANIZATION SHOULD BE CONTACTED FOR THE LATEST REVISION.		FINISH	APPLICATION SPEC NOT AVAILABLE	WEIGHT	SIZE CAGE CODE DRAWING NO A3 00779 C=51863
CUSTOMER DRAWING				SCALE	SHEET 2 of 2		REV 22