

4

3

2

1

THIS DRAWING IS UNPUBLISHED. RELEASED FOR PUBLICATION
 © COPYRIGHT - By - ALL RIGHTS RESERVED.

LOC	DIST	REVISIONS				
P	LTR	DESCRIPTION	DATE	DWN	APVD	
G	14	M2	REVISED PER ECO-11-004587	11MAR11	RK HMR	

AMP WIRE RANGE	Listed	LR7189 Certified
16-14 AWG SOLID OR STRANDED	16-14 AWG SOLID OR STRANDED	16-14 AWG SOLID OR STRANDED

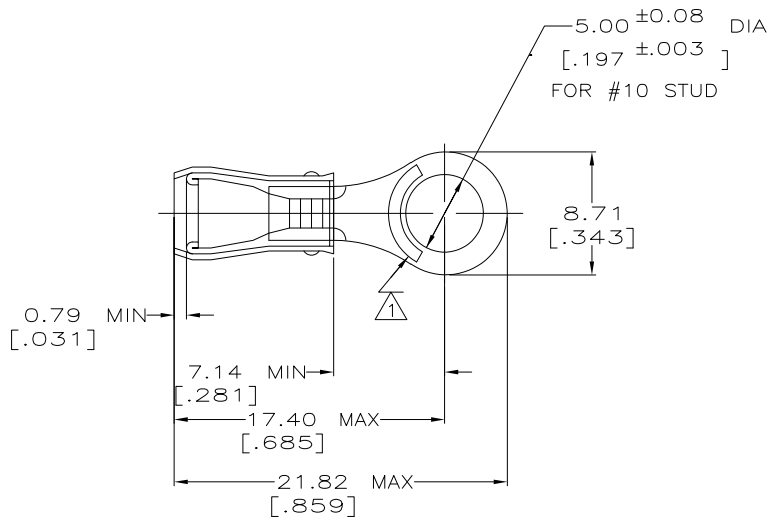

- 1 STAMP AMP 16-14* APPROX AS SHOWN
 STAMP MAY BE ON TOP OR BOTTOM.
 2 WIRE INSUL DIA, 2.92-4.32 [.115-.170]
 3 TONGUE MATERIAL THK, 0.79±0.05 [.031±.002]
 4 SUPERSEDED BY 8-36160-5

4	-25	LOOSE PIECE, BLS	9-36160-4
	50	LOOSE PIECE, BAG	8-36160-5
4	5	LOOSE PIECE, BLS	8-36160-4
	100	LOOSE PIECE, BOX	8-36160-1
	5000	ON TAPE, REEL	2-36160-1
	1000	LOOSE PIECE	36160
	QUANTITY	PACKAGE TYPE	PART NO

AMP INCORPORATED CUSTOMER SERVICE SYSTEMS		MAX RECOMMENDED OPERATING TEMPERATURE: 105° c [221° F]	DIMENSIONS: INCHES	TOLERANCES UNLESS OTHERWISE SPECIFIED: 0 PLC ± - 1 PLC ± - 2 PLC ± 0.20[.008] 3 PLC ± - 4 PLC ± - ANGLES ± -	DWN JR RUTH 17DEC99 CHK RE HERSEY 17DEC99 APVD T MICHELUTTI 17DEC99	TE Connectivity				
FOR ADDITIONAL PRODUCT INFORMATION OR COPIES OF DRAWINGS AND TECHNICAL DOCUMENTS	PRODUCT INFORMATION CENTER 1-800-522-6752	VOLTAGE RATING: 300 V MAX			PRODUCT SPEC UL 486A	TERMINAL, RING TONGUE, PIDG™, WIRE SIZE: 16-14 AWG				
FOR APPLICATION TOOLING INFORMATION	TOOLING ASSISTANCE CENTER 1-800-722-1111	WIRE CROSS SECTIONAL AREA RANGE: 1.04-2.62mm²			APPLICATION SPEC 114-2157	SIZE A3	CAGE CODE 00779	DRAWING NO C=36160	RESTRICTED TO -	
FOR ORDER ENTRY	1-800-526-5142	THIS DRAWING IS A CONTROLLED DOCUMENT FOR AMP INCORPORATED. IT IS SUBJECT TO CHANGE AND THE CONTROLLING ENGINEERING ORGANIZATION SHOULD BE CONTACTED FOR THE LATEST REVISION.		MATERIAL COPPER ASTM B-152 SLEEVE BLUE NYLON	FINISH TIN PLATE ASTM B545	WEIGHT -	CUSTOMER DRAWING	SCALE 4:1	SHEET 1 OF 1	REV M2

1470-19 (3/11)