

4

3

2

1

THIS DRAWING IS UNPUBLISHED. RELEASED FOR PUBLICATION
 © COPYRIGHT - By - ALL RIGHTS RESERVED.

LOC	DIST	REVISIONS			
P	LTR	DESCRIPTION	DATE	DMN	APVD
G	14	R1	REVISED PER ECO-11-004587	11MAR11	RK HMR

AMP WIRE RANGE	Listed	LR7189 Certified
22-16 AWG SOLID OR STRANDED	22-16 AWG SOLID OR STRANDED	22-16 AWG SOLID OR STRANDED

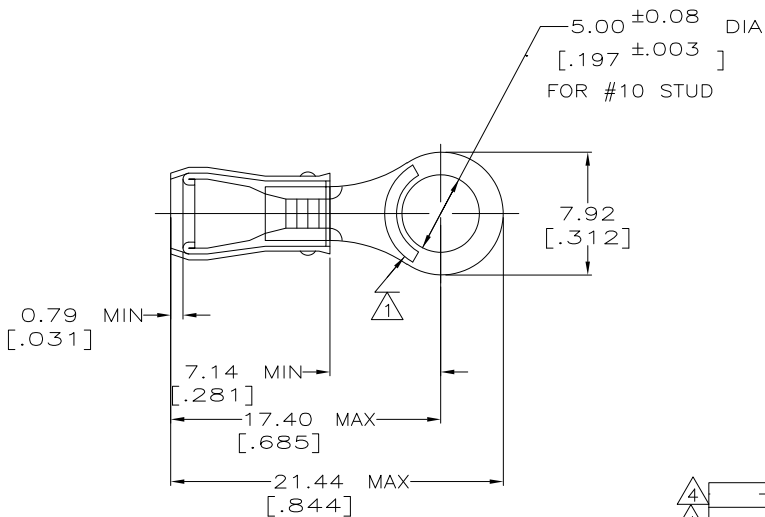

- ① STAMP AMP 22-18* APPROX AS SHOWN
22-16 TERMINALS ARE STAMPED 22-18 IN ACCORDANCE WITH MILITARY SPEC MIL-T-7928
COMMERCIAL WIRE RANGE IS 22-16
- 2 WIRE INSUL DIA, 2.67-3.56 [0.105-0.140]
- 3 TONGUE MATERIAL THK, 0.79±0.05 [0.031 ±0.002]
- ④ SUPERSEDED BY 8-36154-5

④	-	-	25	LOOSE PIECE, BLS	9-36154-4
④	-	-	5	LOOSE PIECE, BLS	8-36154-4
-	-	-	50	LOOSE PIECE, BAG	8-36154-5
-	-	-	100	LOOSE PIECE, BOX	8-36154-1
-	MS 25036-103 CLASS 2	-	5000	ON TAPE, REEL	2-36154-2
-	MS 25036-103 CLASS 1 & 2	-	1000	LOOSE PIECE	36154
MILITARY P/N AND CLASS				QUANTITY	PART NO

**AMP INCORPORATED
CUSTOMER SERVICE SYSTEMS**

FOR ADDITIONAL PRODUCT INFORMATION OR COPIES OF DRAWINGS AND TECHNICAL DOCUMENTS
 PRODUCT INFORMATION CENTER
 1-800-522-6752

FOR APPLICATION TOOLING INFORMATION
 TOOLING ASSISTANCE CENTER
 1-800-722-1111

FOR ORDER ENTRY
 1-800-526-5142

MAX. RECOMMENDED OPERATING TEMPERATURE:
 105° C [221° F]

VOLTAGE RATING:
 300 V MAX

WIRE CROSS SECTIONAL AREA RANGE:
 0.26-1.65mm² [509-3,260] CIR MILS

THIS DRAWING IS A CONTROLLED DOCUMENT.

DIMENSIONS: MM [INCHES]

TOLERANCES UNLESS OTHERWISE SPECIFIED:
 0 PLC ± -
 1 PLC ± -
 2 PLC ± 0.20 [0.008]
 3 PLC ± -
 4 PLC ± -
 ANGLES ± -

MATERIAL: COPPER ASTM B-152 SLEEVE RED NYLON

FINISH: TIN PLATE PER ASTM B 545

DWN DK SCHRUM 02/16/93
 CHK RE HERSEY 4/28/93
 APVD ML ELLIS 4/28/93

TE TE Connectivity

NAME: TERMINAL, RING TONGUE, PIDG™, WIRE SIZE : 22-16 AWG

PRODUCT SPEC: UL 486A

APPLICATION SPEC: NOT AVAILABLE

WEIGHT: -

SIZE: A3 CAGE CODE: 00779 DRAWING NO: C-36154 RESTRICTED TO: -

CUSTOMER DRAWING SCALE: 4:1 SHEET: 1 OF 1 REV: R1