

THE DRAWING IS UNPUBLISHED. RELEASED FOR PUBLICATION. ALL RIGHTS RESERVED.

LOC	QTY	REV	DESCRIPTION	DATE	BY	APP
G	14	E1	REVISED PER ECO-11-004820	11MAR11	RK	HMR

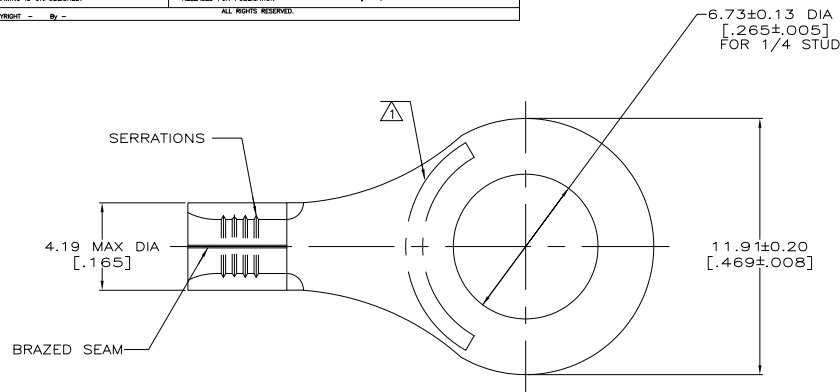

<b>AMP</b> WIRE RANGE	E13288 Listed
16-14 AWG SOLID OR STRANDED	16-14 AWG SOLID OR STRANDED
<b>LR7189</b> Certified	MILITARY P/N AND CLASS
16-14 AWG SOLID OR STRANDED	NOT APPLICABLE

- △ STAMP AMP 16-14\* APPROX AS SHOWN
- △ 0.00254 [.000100] MIN TIN PER ASTM B-545.
- △ CLEANED, UNPLATED

<b>AMP INCORPORATED CUSTOMER SERVICE SYSTEMS</b>		MAX RECOMMENDED OPERATING TEMPERATURE: 170° C MAX
FOR ADDITIONAL PRODUCT INFORMATION OR COPIES OF DRAWINGS AND TECHNICAL DOCUMENTS	PRODUCT INFORMATION CENTER 1-800-522-6752	VOLTAGE RATING: NOT APPLICABLE
FOR APPLICATION TOOLING INFORMATION	TOOLING ASSISTANCE CENTER 1-800-722-1111	WIRE CROSS SECTIONAL AREA RANGE: 1.04-2.62mm <sup>2</sup> [2,050-5,180] CIR MILS SOLID OR STRANDED
FOR ORDER ENTRY	1-800-526-5142	THIS DRAWING IS A CONTROLLED DOCUMENT FOR AMP INCORPORATED. IT IS SUBJECT TO CHANGE AND THE CONTROLLING ENGINEERING ORGANIZATION SHOULD BE CONTACTED FOR THE LATEST REVISION.

△	-	LOOSE PIECE	34124-1
△	100	LOOSE PIECE, BOX SPECIAL (NO WINDOW)	8-34124-5
	100	LOOSE PIECE, BOX	8-34124-1
	5000	ON TAPE	2-34124-1
	----	LOOSE PIECE	34124
FINISH	QUANTITY	PACKAGING TYPE	PART NO

THIS DRAWING IS A CONTROLLED DOCUMENT.		DA BRINKMAN 3-17-83	<b>TE</b> TE Connectivity	
DIMENSIONS: MM [INCHES]		DA PATTERSON 3-17-83	TERMINAL, RING TONGUE, SOLISTRAND	
TO DIMENSIONS UNLESS OTHERWISE SPECIFIED:		DE MILLER 3-17-83	SIZE CASE CODE DRAWING NO RESTRICTED TO	
MATERIAL: COPPER PER ASTM-B-152 ANNEALED		PRODUCT SPEC: APPLICATION SPEC	A2 00779 © 34124	
FINISH: ANGLE		WEIGHT: CUSTOMER DRAWING	SCALE: 8:1 SHEET 1 of 1 REV E1	

1471-9 (3/11)

34124

A