

4

3

2

1

THIS DRAWING IS UNPUBLISHED. RELEASED FOR PUBLICATION  
 © COPYRIGHT 64 BY TYCO ELECTRONICS CORPORATION. ALL INTERNATIONAL RIGHTS RESERVED.

LOC	DIST	REVISIONS			
P	LTR	DESCRIPTION	DATE	BY	APP'D
AF	50				
P		REVISED PER ECR-05-008189	24NOV08	HMR	DD

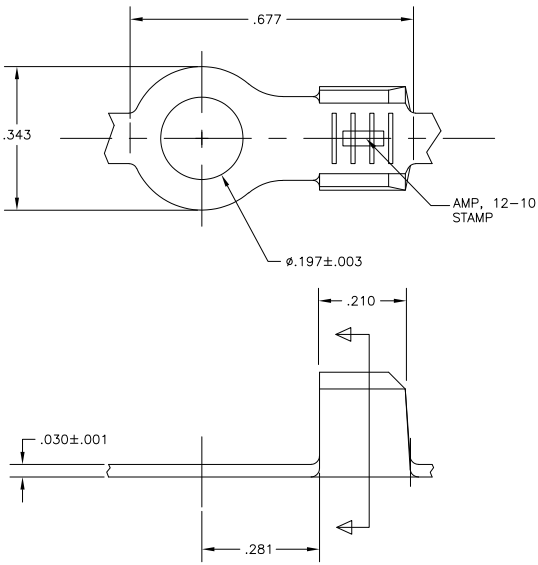

- 1 CONTINUOUS STRIP ON REELS.
- 2 TIN PLATING.
- 3 NICKEL PLATING.
- 4 REDUCED PACKAGE QUANTITY.
- 5 PRELIMINARY - NOT FOR PRODUCTION.

OBSOLETE	12-10 AWG	△	△	40696-2
	12-10 AWG	△		40696-1
	12-10 AWG	△		40696
	WIRE RANGE	FINISH		PART NUMBER

THIS DRAWING IS A CONTROLLED DOCUMENT.		DWG: MICHAEL S. FEHR 14FEB2002 CHK: DONALD F. DECKER 14FEB2002 APP: DONALD F. DECKER 14FEB2002 PRODUCT SPEC:	Tyco Electronics Corporation Harrisburg, PA 17105-3608
DIMENSIONS: INCHES 0 PLG ± .001 1 PLG ± .001 2 PLG ± .010 3 PLG ± .010 4 PLG ± .010 ANGLES ± .1°	FINISH: SEE TABLE	NAME: DONALD F. DECKER APPLICATION SPEC:	TYPICAL DRAWING SIZE: A2 CASE CODE: 00779 DRAWING NO: C-40696 RESTRICTED TO:
MATERIAL: 082 BRASS		CUSTOMER DRAWING	
		SCALE: 6:1	SHEET: 1 of 1 REV: P

1471-9 (1/08)

40696

A