

4 3

DRAWING MADE IN THIRD ANGLE PROJECTION

THIS DRAWING IS UNPUBLISHED. RELEASED FOR PUBLICATION

© COPYRIGHT 19 BY AMP INCORPORATED, HARRISBURG, PA. ALL INTERNATIONAL RIGHTS RESERVED. AMP PRODUCTS MAY BE COVERED BY U.S. AND FOREIGN PATENTS AND/OR PATENTS PENDING.

2 1

LOC		DIST		REVISIONS			
P	F	ZONE	LTR	DESCRIPTION	DATE	APPROVED	
AF	50		J	OBSOLETE -3 PER 0710-0273-96	15/JUL/88	PF/GY	

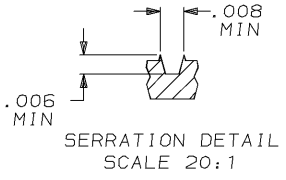
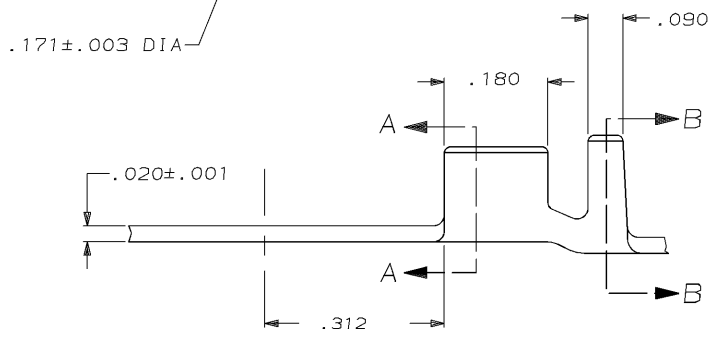
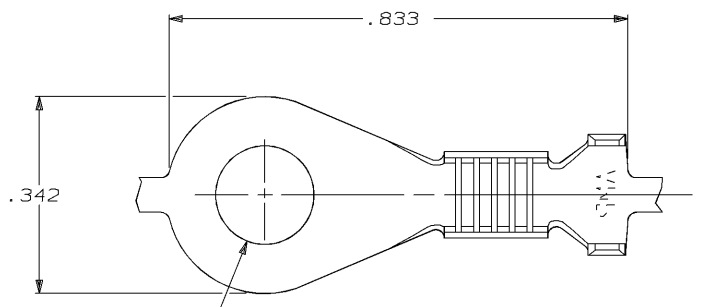

1 TIN PL .000200 MIN PER MIL-T-10727 OVER
COPPER PL .000100 MIN PER MIL-C-14550

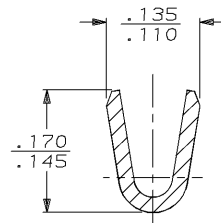

SECTION A-A
SCALE 8:1

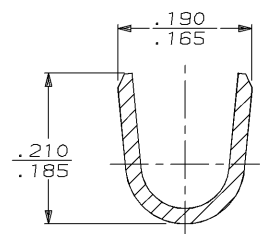

SECTION B-B
SCALE 8:1

FINISH	INSULATION RANGE	MAGNET WIRE SIZE	PART NO
TIN PL	.100-.140	18-14	60320-3
	.100-.140	18-14	60320-2
	.100-.140	18-14	60320-1

UNLESS OTHERWISE SPECIFIED DIMENSIONS ARE IN INCHES TOLERANCES ON:		DR P FORTNEY 6/4/87	AMP INCORPORATED Harrisburg, Pa. 17105		
2 PL DEC ± -		CHK G YETTER 1/6/88			
3 PL DEC ± .015		APPD RP FRANTZ 1/7/88	NAME RING, AMPLIVAR		
ANGLES # -		APPD TL SHUTTER 1/12/88			
MATERIAL	T1 BRASS	PRODUCT SPEC	SIZE	FSCM NO	DRAWING NO
FINISH	SEE TABLE	APPLICATION SPEC	B	00779	60320
		WEIGHT	SCALE	6:1	SHEET 1 OF 1

AMP 1470-15 REV 10-84

15-JUL-88 07:03:30 amp17755 /usr/dep12122/dwg12122/lu.rs

CUSTOMER DRAWING