

4

3

2

1

THIS DRAWING IS UNPUBLISHED. RELEASED FOR PUBLICATION
 © COPYRIGHT - BY TYCO ELECTRONICS CORPORATION. ALL RIGHTS RESERVED.

LOC	DIST	REVISIONS				
P	LTR	DESCRIPTION	DATE	DWN	APVD	
AF	50	B	REV PER OG3A-0132-05	24MAY05	JR	DD

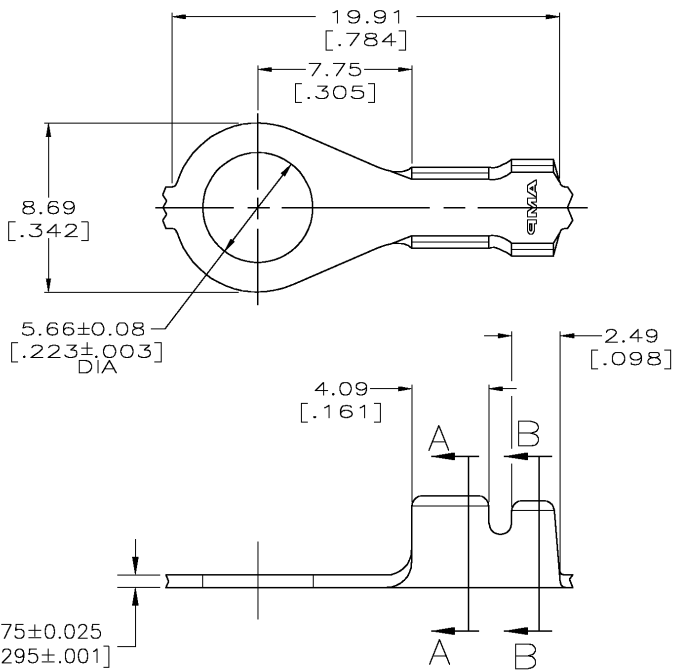

- 1 CONTINUOUS STRIP ON REEL.
- 2 WIRE SIZE IS {#18-#14} AWG
- 3 INSULATION RANGE IS 2.54-3.56 [.100-.140] DIA.

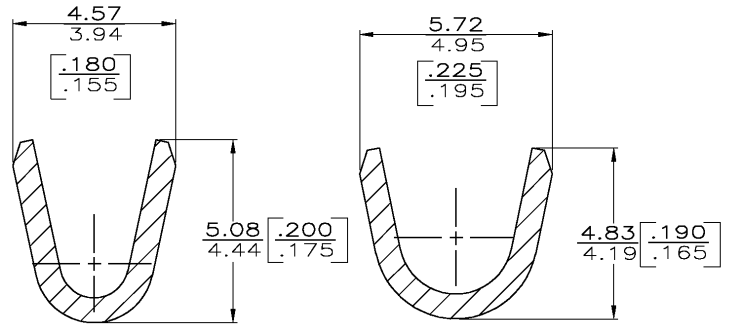

SECTION A-A
SCALE 10:1

SECTION B-B
SCALE 10:1

63872-1
PART NO.

THIS DRAWING IS A CONTROLLED DOCUMENT.		DWN PHILLIP M. FORTNEY 13/OCT/95	tyco Electronics		Tyco Electronics Corporation Harrisburg, Pa 17105-3608
DIMENSIONS: MM [INCHES]		CHK JEFF R RUTH 13/OCT/95	NAME RING		
TOLERANCES UNLESS OTHERWISE SPECIFIED:		APVD G YETTER 13/OCT/95	RESTRICTED TO		
0 PLC	± -	PRODUCT SPEC	-		
1 PLC	± -	APPLICATION SPEC	-		
2 PLC	± 0.25 [.010]	WEIGHT	-		
3 PLC	± -	MATERIAL	082 BRASS		
4 PLC	± -	FINISH	-		
ANGLES	± -	CUSTOMER DRAWING	-		
MATERIAL 082 BRASS		FINISH -	SIZE A3	CAGE CODE 00779	DRAWING NO C-63872
SCALE 5:1			SHEET 1	OF 1	REV B