

THIS DRAWING IS UNPUBLISHED. RELEASED FOR PUBLICATION

© COPYRIGHT 19 BY AMP INCORPORATED, HARRISBURG, PA. ALL INTERNATIONAL RIGHTS RESERVED. AMP PRODUCTS MAY BE COVERED BY U.S. AND FOREIGN PATENTS AND/OR PATENTS PENDING.

P		F		ZONE		LTR		DESCRIPTION		DATE	APPROVED
									REDRAWN	2/6/89	SS/

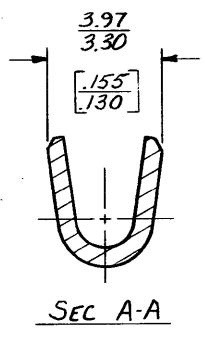
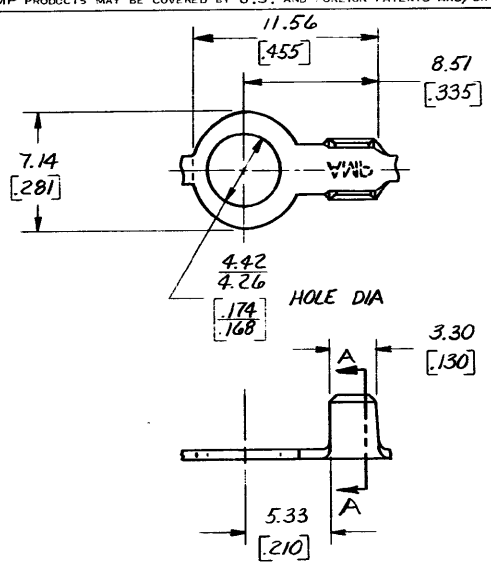

1. DIMS IN BRACKETS ARE IN INCHES.
2. CONTINUOUS STRIP ON REELS

METRIC

UNLESS OTHERWISE SPECIFIED DIMENSIONS ARE IN MILLIMETERS . TOLERANCES ON DECIMALS = ±0.30 [0.015]. ANGLES = ±0.5° [0.025].		CONTRACT NO		0.8 - 2.0 mm ² [#18-#12]		40951	
DR: S. Schaffner 2-6-89		AMP		AMP INCORPORATED		Harrisburg, Pa.	
CHK: J. H. ... 2-6-89		NAME		RING			
MATERIAL: 0.51 BRASS [020]		APPD: J. H. ... 2-6-89		SIZE: B		FSCM NO: 00779	
FINISH: NONE		OTHER APPD:		DRAWING NO: 40951		SHEET	

CUSTOMER DRAWING