

DRAWING MADE IN THIRD ANGLE PROJECTION

THIS DRAWING IS UNPUBLISHED. RELEASED FOR PUBLICATION, 19
 © COPYRIGHT 19 BY AMP INCORPORATED. ALL INTERNATIONAL RIGHTS RESERVED.

LOC	DIST	REVISIONS				DATE	APPD
P	F	ZONE	LTR	DESCRIPTION			
AF	50			C REVISED PER 061A-0211-98	30/JUN/98	PF/DD	

1 CONTINUOUS STRIP ON REELS

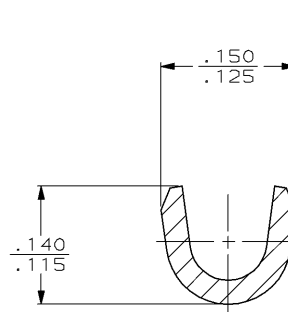
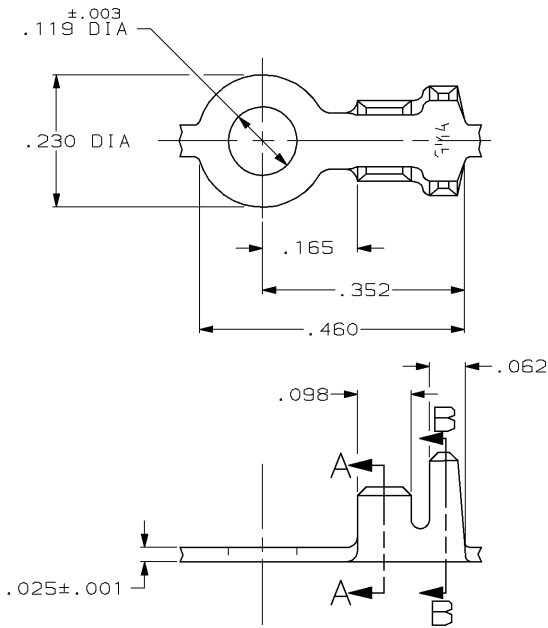

SECTION A-A
SCALE 10:1

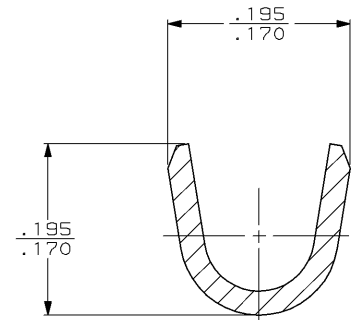

SECTION B-B
SCALE 10:1

	.100-.135 DIA	20-16 AWG	61386-2
	.000080 MIN TIN	.100-.135 DIA	20-16 AWG
FINISH	INSULATION RANGE	WIRE SIZE	PART NO
DO NOT SCALE PRINT. UNLESS SPECIFIED DIMENSIONS IN INCHES TOLERANCES ON: 2 PLC DEC ± 3 PLC DEC ± .015 ANGLES ±	DR 3/21/90 P FURSTNEY CHK 3/21/90 JR RUTH APPD 3/21/90 G YETTER APPD 3/21/90 R KUZO	AMP INCORPORATED Harrisburg, Pa. 17105	
MATERIAL #1 HARD BRASS	PRODUCT SPEC -	NAME RING	
FINISH SEE TABLE	APPLICATION SPEC -	SIZE B	CAGE CODE 00779
	WEIGHT -	DRAWING NO 61386	SHEET 1 OF 1
		SCALE 6:1	

CUSTOMER DRAWING

AMP 1470-15 REV 6-89
 30-JUN-98 12:35:08 amp1795 /home/amp1795/odmod