

4

3

2

1

THIS DRAWING IS UNPUBLISHED. RELEASED FOR PUBLICATION
 © COPYRIGHT - By - ALL RIGHTS RESERVED.

LOC		DIST		REVISIONS			
P	LTR	DESCRIPTION		DATE	DWN	APVD	
	S1	REVISED PER ECO-11-004587		11MAR11	RK	HMR	

1 CONTINUOUS STRIP ON REEL.

△ 2 TIN PLATING.

△ 3 NICKEL PLATING.

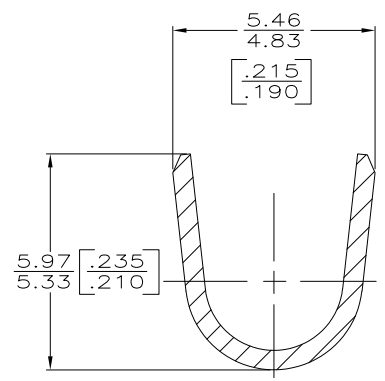
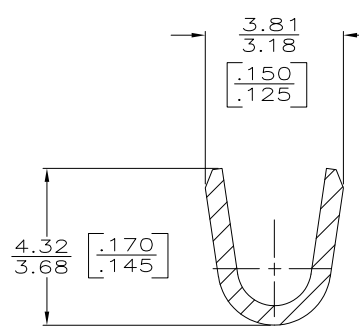
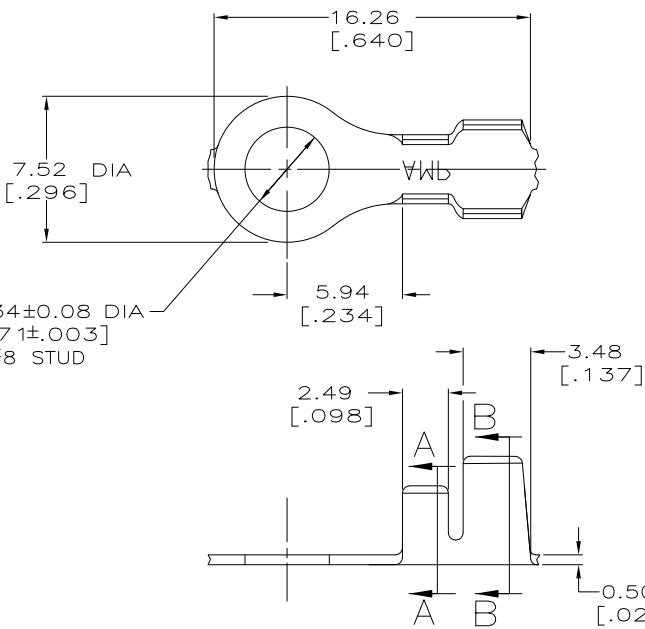

SECTION A-A SCALE 10:1

SECTION B-B SCALE 10:1

△ 3	T3 STEEL	3.05-4.32 DIA	[18-14] AWG	41332-1
△ 2	082 BRASS	[.120-.170]		41332
FINISH	MATERIAL	INSULATION RANGE	WIRE RANGE	PART NO

F OR O	4.57 [.180]	4.06 [.160]	F	3.05 [.120]	1.96[.077] [14] 1.73[.068] [16] 1.60[.063] [18] ±0.051[±.002] HEIGHT	WIRE
TYPE	WIDTH	STRIP LENGTH ±0.38 ±[.015]	TYPE	WIDTH		
INSUL BARREL CRIMP			WIRE BARREL CRIMP			

THIS DRAWING IS A CONTROLLED DOCUMENT.
 DIMENSIONS: INCHES
 TOLERANCES UNLESS OTHERWISE SPECIFIED:
 0 PLC ± -
 1 PLC ± -
 2 PLC ± 0.25 [010]
 3 PLC ± -
 4 PLC ± -
 ANGLES ± -
 MATERIAL SEE TABLE
 FINISH SEE TABLE

DWN P FORTNEY 7/22/91	STE TE Connectivity		RING	
CHK MS FEHER 8/8/91			RESTRICTED TO	
APVD G YETTER 8/12/91	NAME	SIZE A3	CAGE CODE 00779	DRAWING NO C-41332
PRODUCT SPEC	APPLICATION SPEC	WEIGHT	CUSTOMER DRAWING	SCALE 5:1 SHEET 1 OF 1 REV S1