

THIS DRAWING IS UNPUBLISHED. RELEASED FOR PUBLICATION  
 © COPYRIGHT 19 BY AMP INCORPORATED. ALL INTERNATIONAL RIGHTS RESERVED.

LOC	DIST	P	F	ZONE	LTR	DESCRIPTION	DATE	APPD
G	14				C	REV & REDRAWN PER 0720-0040-93	3-26-93	10 DAP

**METRIC**  
 DIMENSIONS LISTED IN mm [ INCHES ]

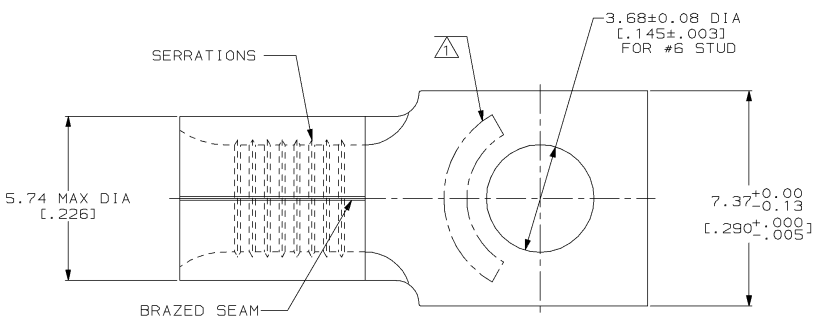

<b>AMP</b> WIRE RANGE	<b>UL</b> E13288 Listed
12-10 AWG SOLID OR STRANDED	12-10 AWG STRANDED
<b>UL</b> LR7189 Certified	MILITARY P/N AND CLASS
12-10 AWG SOLID OR STRANDED	NOT APPLICABLE

△ STAMP AMP 12-10\* APPROX AS SHOWN

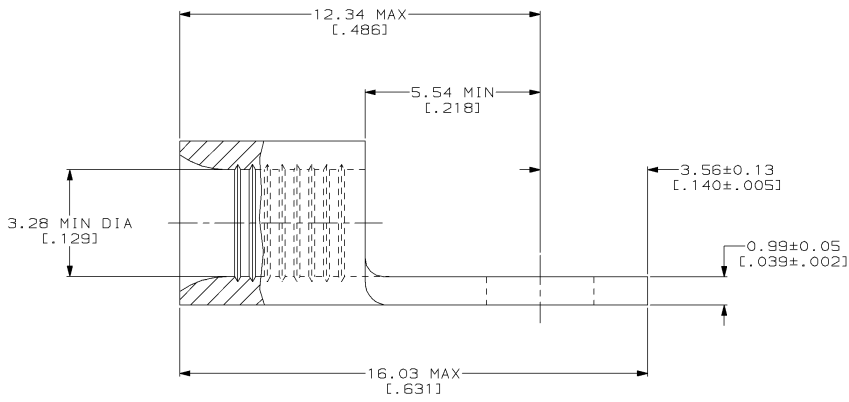

2500	ON TAPE	2-321499-1
----	LOOSE PIECE	321499
QUANTITY	PACKAGING TYPE	PART NO

**AMP INCORPORATED**  
**CUSTOMER SERVICE SYSTEMS**

MAX RECOMMENDED OPERATING TEMPERATURE:  
 170°C MAX

DO NOT SCALE PRINT.  
 UNLESS SPECIFIED DIMENSIONS IN INCHES  
 TOLERANCES ON:  
 2 PLC DEC ± -  
 3 PLC DEC ± -  
 ANGLES ± -

DR 3-26-93  
 TA BRINKMAN  
 CHK 3-26-93  
 DA PATTERSON  
 APPD 3-26-93  
 DE MILLER

**AMP** AMP Incorporated  
 Harrisburg, PA 17105-3608

FOR ADDITIONAL PRODUCT INFORMATION OR COPIES OF DRAWINGS AND TECHNICAL DOCUMENTS

PRODUCT INFORMATION CENTER  
 1-800-522-6752

VOLTAGE RATING:  
 NOT APPLICABLE

MATERIAL  
 COPPER PER  
 ASTM B-152  
 ANNEALED

APPD 3-26-93  
 JL MECKLEY  
 PRODUCT SPEC

NAME  
**TERMINAL, RECTANGULAR TONGUE, SOLISTRAND™**

FOR APPLICATION TOOLING INFORMATION

TOOLING ASSISTANCE CENTER  
 1-800-722-1111

WIRE CROSS SECTIONAL AREA RANGE:  
 2.62-6.64mm² [5, 180-13, 100] CIR MILS  
 SOLID OR STRANDED

FINISH  
 T1N PLATE  
 0.00254 [ .000100 ] MIN  
 THK PER MIL-T-10727

APPLICATION SPEC  
 -

SIZE  
 CAGE CODE  
**00779**  
 DRAWING NO  
**321499**

FOR ORDER ENTRY

1-800-526-5142

THIS DRAWING IS A CONTROLLED DOCUMENT FOR AMP INCORPORATED. IT IS SUBJECT TO CHANGE AND THE CONTROLLING ENGINEERING ORGANIZATION SHOULD BE CONTACTED FOR THE LATEST REVISION.

WEIGHT  
 -

SCALE  
 10:1

SHEET  
 1 OF 1

10\_SEP\_1993 12:21:30 AMP26463 <U5128A>DEPT1123>DWG1123>U\_SQ1STRAND>U\_INL\_INE

CUSTOMER DRAWING