

THIS COPY IS PROVIDED ON A RESTRICTED BASIS AND IS NOT TO BE USED IN ANY WAY DETRIMENTAL TO THE INTERESTS OF PANDUIT CORP.

PART NUMBER		TAB SIZE	AWG WIRE RANGE (mm ²)	HOUSING COLOR	MAX WIRE INSUL DIA	DIMENSIONS in.			
PREFIX	PK					A ± .03 (.8)	B ± .02 (.5)	W ± .01 (.3)	X ± .03 (.8)
DNFR18-250B	-L -M	.250 X .032 (6,3 X 0,8)	22-18 (0,5-1,0)	RED	.130 (3,30)	.78 (19,8)	.20 (5,1)	.36 (9,1)	.62 (15,7)
DNFR14-250B	-L -M	.250 X .032 (6,3 X 0,8)	16-14 (1,5-2,5)	BLUE	.155 (3,94)	.78 (19,8)	.20 (5,1)	.36 (9,1)	.63 (16,0)
DNFR18-205B	-L -M	.205 X .032 (5,2 X 0,8) OR .187 X .032 (4,8 X 0,8)	22-18 (0,5-1,0)	RED	.130 (3,30)	.78 (19,8)	.20 (5,1)	.36 (9,1)	.62 (15,7)
DNFR14-205B	-L -M	.205 X .032 (5,2 X 0,8) OR .187 X .032 (4,8 X 0,8)	16-14 (1,5-2,5)	BLUE	.155 (3,94)	.78 (19,8)	.20 (5,1)	.36 (9,1)	.63 (16,0)
DNFR18-206B	-L -M	.205 X .020 (5,2 X 0,5) OR .187 X .020 (4,8 X 0,5)	22-18 (0,5-1,0)	RED	.130 (3,30)	.78 (19,8)	.20 (5,1)	.36 (9,1)	.62 (15,7)
DNFR14-206B	-L -M	.205 X .020 (5,2 X 0,5) OR .187 X .020 (4,8 X 0,5)	16-14 (1,5-2,5)	BLUE	.155 (3,94)	.78 (19,8)	.20 (5,1)	.36 (9,1)	.63 (16,0)



LISTED
20H3
E78522



CERTIFIED
LR31212

NOTES:

- USED FOR:
 - A. 600V MAX VOLTAGE RATING
 - B. 221°F (105°C) MAX INSULATION TEMP. RATING
 - C. STRANDED COPPER WIRE ONLY
- FIRST INSERTION FORCE - 12 LB. (53N) MAX
FIRST WITHDRAWAL FORCE - 12 LB. (53N) MAX
6 LB. (27N) MIN
- INSTALLATION TOOLS:
 - A. CT-1525
- WIRE STRIP LENGTH: 9/32 ^{+1/32} ₋₀ (7.1 ^{+0.8} ₋₀)
- MATERIAL USED:
 - A. TERMINAL STAMPING: .018 (.46) (THK) TIN PLATED BRASS
 - B. HOUSING : NYLON
- PACKAGING QTY:
 - A. STD : -L = 50
 - B. BULK : -M = 1000
- DIMENSIONS IN BRACKETS ARE IN MILLIMETERS OR mm²

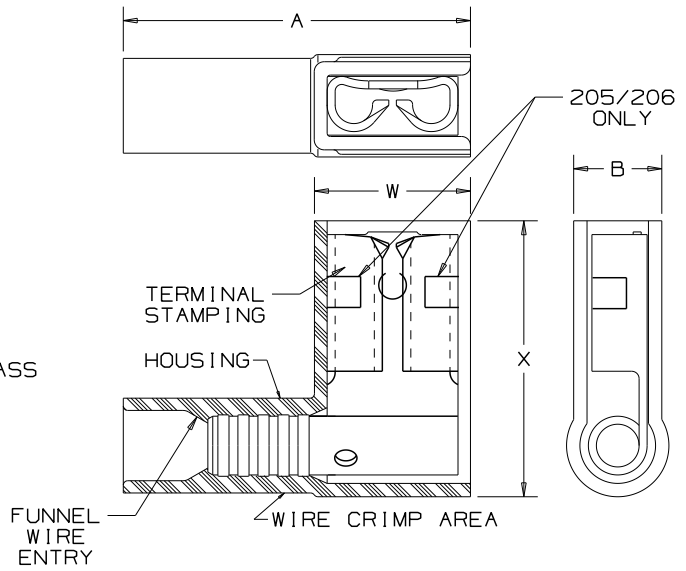

PANDUIT

CORP.

TINLEY PARK, ILLINOIS

MOLDED NYLON INSULATED RIGHT ANGLE FEMALE DISCONNECTS, BUTTED SEAM

07	1/11	SRB	CHANGED PACKAGING CODE FROM C-100 TO L-50
REV	DATE	BY	DESCRIPTION

DRAWN BY	CHK'D	SCALE	DRAWING NO.
DAW	RLS	NONE	A41329